

Model No.DLS714 DC SLIDE COMPOUND MITER SAW

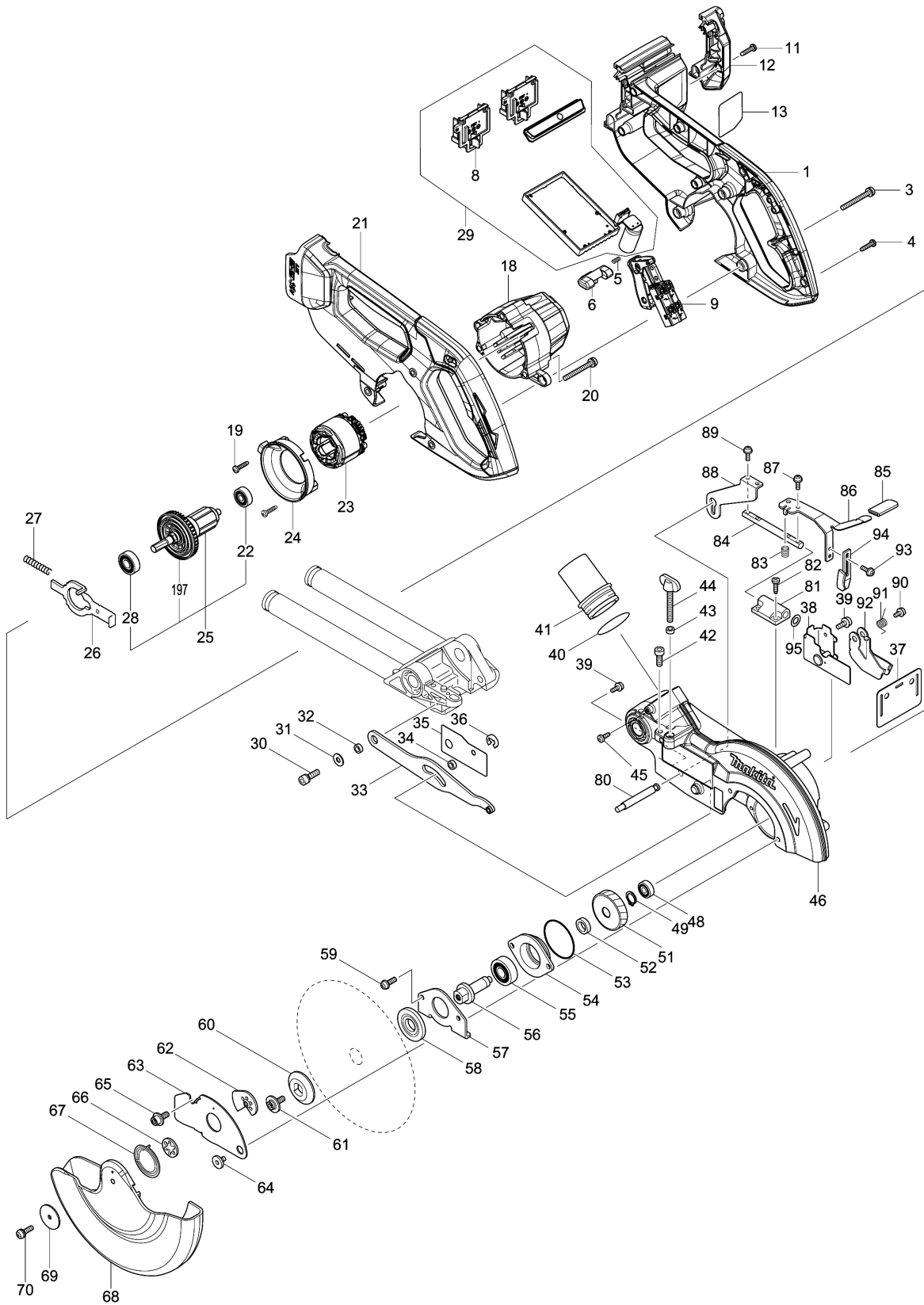

Model No.DLS714 DC SLIDE COMPOUND MITER SAW

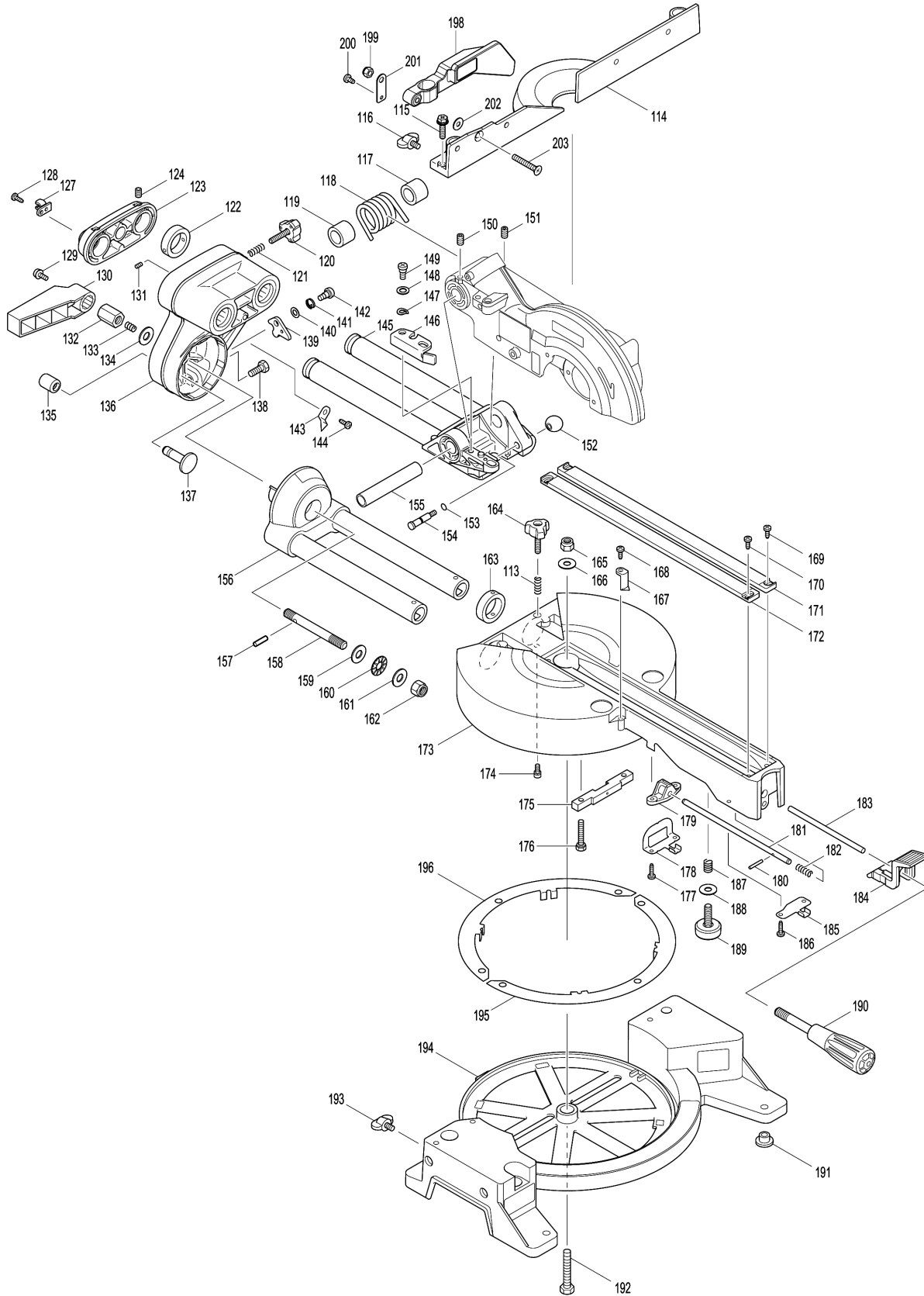

Model No.DLS714 DC SLIDE COMPOUND MITER SAW

Item	Parts No.	Description	I/C	Qty	New/Old	Opt. 1	Opt. 2	Note
001	183B55-3	HANDLE SET		1				
D10		INC. 21						
003	911268-2	PAN HEAD SCREW M5X45		3				
004	265995-6	TAPPING SCREW 4X18		6	*			
004-1	265A48-7	TAPPING SCREW 4X18	O	6				
005	231397-8	COMPRESSION SPRING 4		1				
006	456024-8	LOCK OFF BUTTON		1				
008	644808-8	TERMINAL		2				
009	650756-1	SWITCH		1				
011	265995-6	TAPPING SCREW 4X18		3	*			
011-1	265A48-7	TAPPING SCREW 4X18	O	3				
012	143268-6	HANDLE COVER COMPLETE		1				
C10	263005-3	RUBBER PIN 6		1				
013	851E60-3	DLS714 NAME PLATE		1				
018	456022-2	MOTOR HOUSING		1				
019	265995-6	TAPPING SCREW 4X18		2	*			
019-1	265A48-7	TAPPING SCREW 4X18	O	2				
020	911268-2	PAN HEAD SCREW M5X45		3				
021	183B55-3	HANDLE SET		1				
D10		INC. 1						
022	210017-7	BALL BEARING 607DDW		1				
023	629157-4	STATOR		1				
024	456023-0	BAFFLE PLATE		1				
025A	519373-5	ROTOR ASS'Y		1	*			
D10		INC. 22,28,197			*			
025-1A	519373-5	ROTOR ASS'Y	O	1				
D10		INC. 22,28,197						
025-1B	519373-5	ROTOR ASS'Y		1				
D10		INC. 22,28,197						
026	344681-3	SHAFT LOCK		1				
027	233092-6	COMPRESSION SPRING 5		1				
028	211092-6	BALL BEARING 629DDW		1				
029A	143291-1	CONTROLLER COMPLETE		1	*			
D10		INC. 8			*			
029-1A	140B40-9	CONTROLLER COMPLETE	<	1				
D10		INC. 8						
029-1B	140B40-9	CONTROLLER COMPLETE		1				
D10		INC. 8						
030	922331-6	HEX. SOCKET HEAD BOLT M6X20		1				
031	253804-1	FLAT WASHER 6		1				
032	257163-5	RING 6		1				
033	154643-1	LINK PLATE COMPLETE		1				

Please order the parts with part number.

Print Date 26/3/2020

Model No.DLS714 DC SLIDE COMPOUND MITER SAW

Item	Parts No.	Description	I/C	Qty	New/Old	Opt. 1	Opt. 2	Note
034	257163-5	RING 6		1				
035	346330-8	LINK COVER		1				
036	961018-5	STOP RING E-5		1				
037A	421626-9	GUARD		1				
037B	424045-8	GUARD		1				
038A	165414-1	GUARD PLATE COMPLETE		1				
038B	345438-5	GUARD PLATE		1				
039	911113-1	PAN HEAD SCREW M4X10 WITH WR		1				
040	213460-9	O RING 35		1				
041	419277-0	DUST NOZZLE		1				
042	266757-5	HEX. SOCKET HEAD BOLT M6X16		1				
043	262001-8	URETHANE RING 5		1				
044	265717-4	SCREW M6X43		1				
045	266026-4	TAPPING SCREW BIND CT 4X12		1				
046A	143350-1	BLADE CASE COMPLETE		1				
046B	140699-0	BLADE CASE COMPLETE		1				
C30	810968-0	CAUTION LABEL		1				
C10	263002-9	RUBBER PIN 4		1				
C20	263005-3	RUBBER PIN 6		1				
048	210017-7	BALL BEARING 607DDW		1				
049	961052-5	RETAINING RING S-12		1				
051	227810-2	HELICAL GEAR 53		1				
052	257088-3	RING 12		1				
053	213623-7	O RING 46		1				
054	317193-9	BEARING BOX		1				
055	211129-9	BALL BEARING 6201DDW		1				
056	323798-5	SPINDLE		1				
057	285736-4	BEARING RETAINER 58		1				
058	224370-5	INNER FLANGE 40		1				
059	911223-4	PAN HEAD SCREW M5X16		2				
060	224275-9	OUTER FLANGE 40		1				
061	266733-9	HEX. S.F.H. BOLT M6X16		1				
062	345585-2	CENTER PLATE		1				
063	346232-8	CENTER COVER		1				
064	265985-9	HEX.SOCKET HEAD BOLT M6		1				
065	266732-1	HEX. SOCKET HEAD BOLT M6X16		1				
066	345589-4	CENTER WASHER		1				
067	231934-8	SPIRAL SPRING 26		1				
068A	453298-2	SAFETY COVER		1				
068B	458786-4	SAFETY COVER		1				

Model No.DLS714 DC SLIDE COMPOUND MITER SAW

Item	Parts No.	Description	I/C	Qty	New/Old	Opt. 1	Opt. 2	Note
069	267136-0	FLAT WASHER 5		1				
070	265491-4	H.S. BUTTON HEAD BOLT M5X16		1				
080A	324455-8	LOCK PIN		1				
081A	452134-9	ROD HOLDER		1				
082A	266034-5	TAPPING SCREW CT 4X16		2				
083A	231316-4	COMPRESSION SPRING 7		1				
084A	325980-2	ROD 8		1				
085A	421589-9	CAP		1				
086A	346320-1	LOCK LEVER		1				
087A	911113-1	PAN HEAD SCREW M4X10 WITH WR		2				
088A	346322-7	LOCK PLATE		1				
089A	911113-1	PAN HEAD SCREW M4X10 WITH WR		2				
090A	911114-9	PAN HEAD SCREW M4X10		1				
091A	231690-0	TORSION SPRING 8		1				
092A	346550-4	GUARD		1				
093A	911113-1	PAN HEAD SCREW M4X10 WITH WR		2				
094A	346321-9	SUB LEVER		1				
095A	253215-0	FLAT WASHER 8		1				
113	231325-3	COMPRESSION SPRING 6		1				
114	319193-5	GUIDE FENCE		1				
115	922344-7	H.S.H.BOLT M6X25 WITH WG		3				
116	251887-5	SCREW M6X10		1				
117	416535-5	SLEEVE 17		1				
118	233520-1	TORSION SPRING 28		1				
119	416535-5	SLEEVE 17		1				
120	265790-4	THUMB SCREW M6X28		1				
121	231325-3	COMPRESSION SPRING 6		1				
122	257214-4	RING 26		1				
123	318651-8	PIPE HOLDER		1				
124	266208-8	H.S.SET SCREW(CUP POINT)M6X8		2				
127	687045-1	STRAIN RELIEF		1				
128	266026-4	TAPPING SCREW BIND CT 4X12		1				
129	911113-1	PAN HEAD SCREW M4X10 WITH WR		1				
130	416006-2	LEVER 100		1				
131	913106-4	SET SCREW M4X8		1				
132	252144-4	HEX. NUT M10-17		1				
133	231266-3	COMPRESSION SPRING 5		1				
134	253024-7	FLAT WASHER 10		1				
135	286236-7	CAP 16		1				

Model No.DLS714 DC SLIDE COMPOUND MITER SAW

Item	Parts No.	Description	I/C	Qty	New/Old	Opt. 1	Opt. 2	Note
136	140609-7	ARM COMPLETE		1				
C10	211376-2	LINEAR BALL BEARING 2560		2				
C20	262077-5	FELT RING 25		4				
C30	263005-3	RUBBER PIN 6		2				
C40	344638-4	CAP 35		2				
137	324295-4	RELEASE PIN		1				
138	266757-5	HEX. SOCKET HEAD BOLT M6X16		2				
139	345299-3	STOPPER PLATE		1				
140	253726-5	FLAT WASHER 6		1				
141	231663-3	TORSION SPRING 8		1				
142	265113-6	+PAN HEAD SCREW M5		1				
143	343678-9	POINTER		1				
144	266026-4	TAPPING SCREW BIND CT 4X12		1				
145	140608-9	FRONT ARM COMPLETE		1				
146	344643-1	STOPPER ARM		1				
147	253948-7	WAVE WASHER 8		1				
148	253835-0	FLAT WASHER 8		1				
149	251267-5	+ PAN HEAD SCREW M6		1				
150	251961-9	H.S.SET SCREW(FLAT POINT)M6X10		1				
151	251961-9	H.S.SET SCREW(FLAT POINT)M6X10		1				
152	271601-3	KNOB 20		1				
153	213021-5	O RING 5		1				
154	324183-5	STOPPER PIN		1				
155	331350-5	PIN 16-90		1				
156	140610-2	ARM HOLDER COMPLETE		1				
C10	816392-5	BEVEL SCALE LABEL		1				
157	256123-4	PIN 5		1				
158	266320-4	SCREW M10		1				
159	253024-7	FLAT WASHER 10		1				
160	216413-7	THRUST NEEDLE CAGE 1024		1				
161	253024-7	FLAT WASHER 10		1				
162	252130-5	HEX. LOCK NUT M10-17		1				
163	257214-4	RING 26		1				
164	265790-4	THUMB SCREW M6X28		1				
165	252105-4	HEX. LOCK NUT M8-13		1				
166	253731-2	FLAT WASHER 8		1				
167	416355-7	INDICATION PLATE		1				
168	266026-4	TAPPING SCREW BIND CT 4X12		1				
169	266026-4	TAPPING SCREW BIND CT 4X12		2				