

**DEUMIDIFICATORI
DEHUMIDIFIERS**

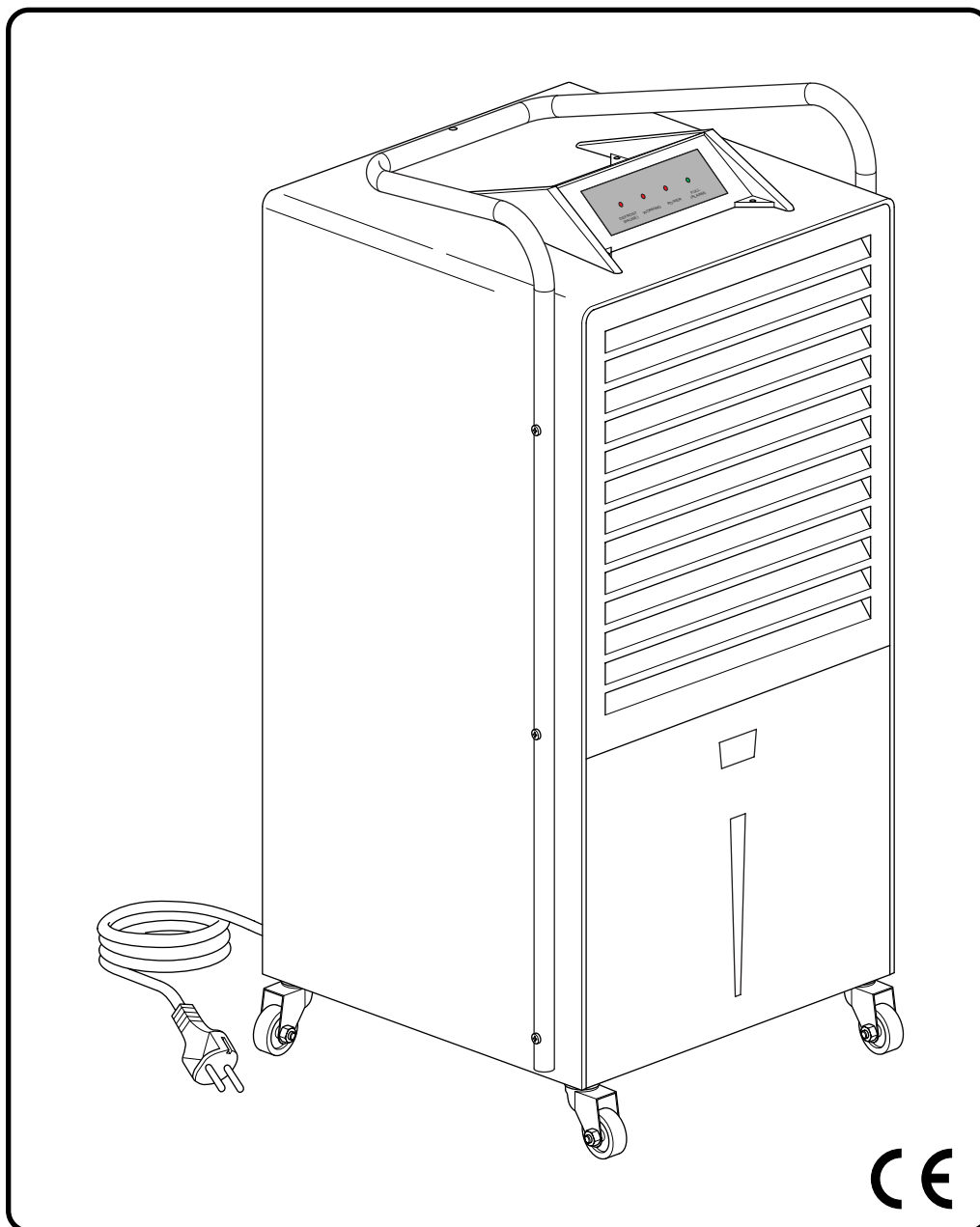

I

GB

FDND 33 - FDND 33 SH

COMPONENTI PARTI DI RICAMBIO
SPARE PARTS DISASSEMBLY

COMPONENTI PARTI DI RICAMBIO - SPARE PARTS DISASSEMBLY

FDND 33

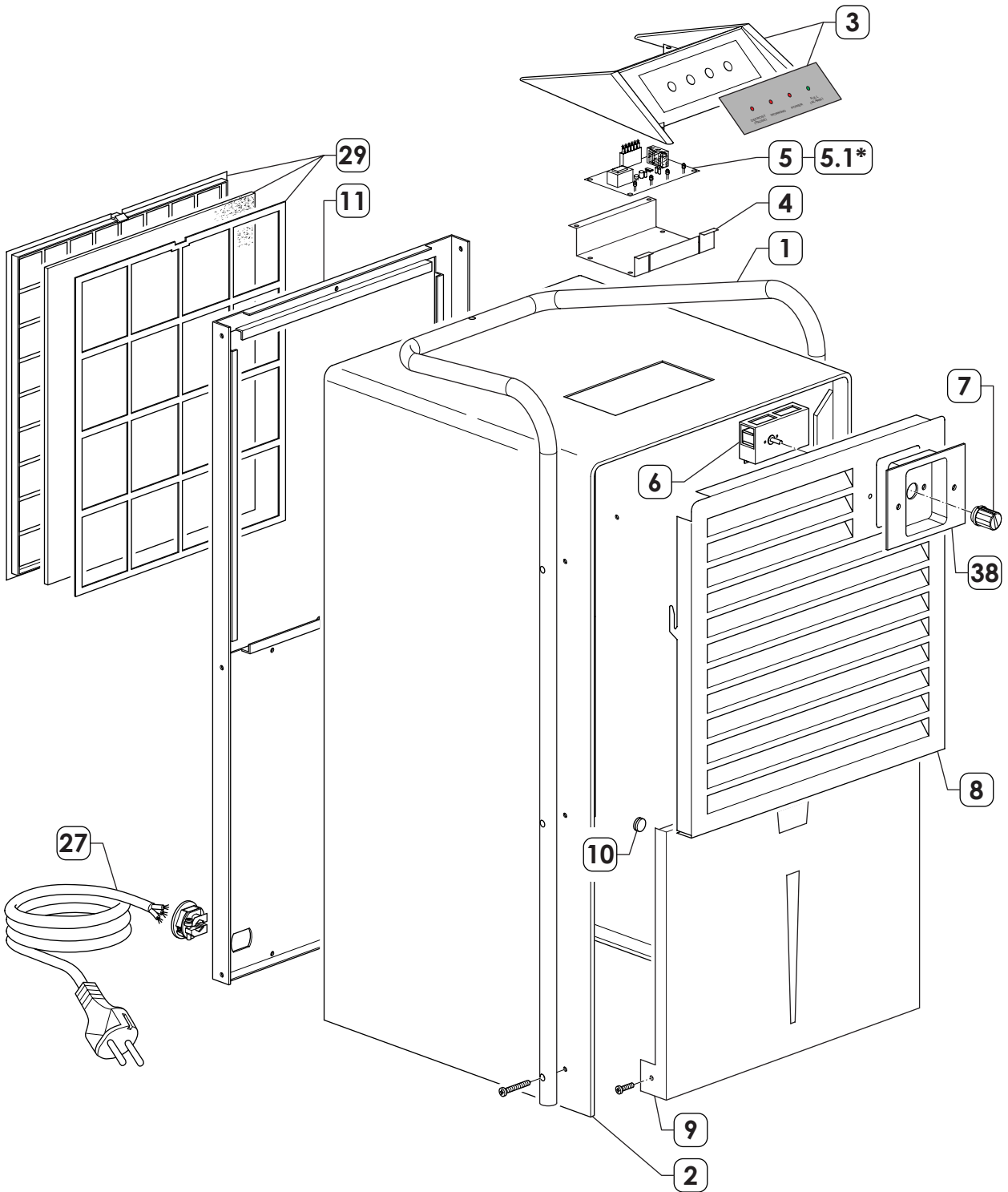

Fig. 1

COMPONENTI PARTI DI RICAMBIO - SPARE PARTS DISASSEMBLY

FDND 33 SH

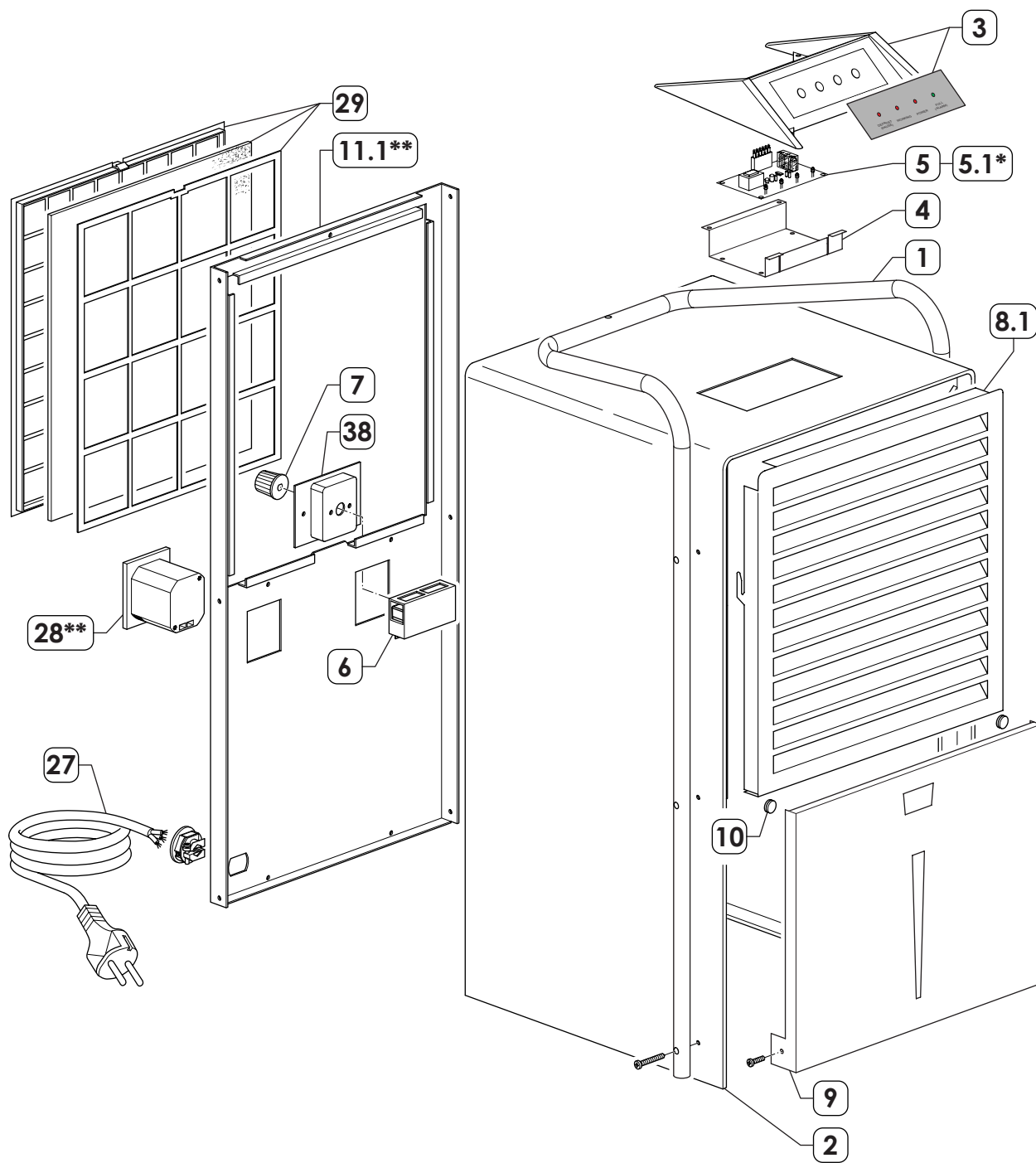

Fig. 2

COMPONENTI PARTI DI RICAMBIO - SPARE PARTS DISASSEMBLY

FDND 33 - FDND 33 SH

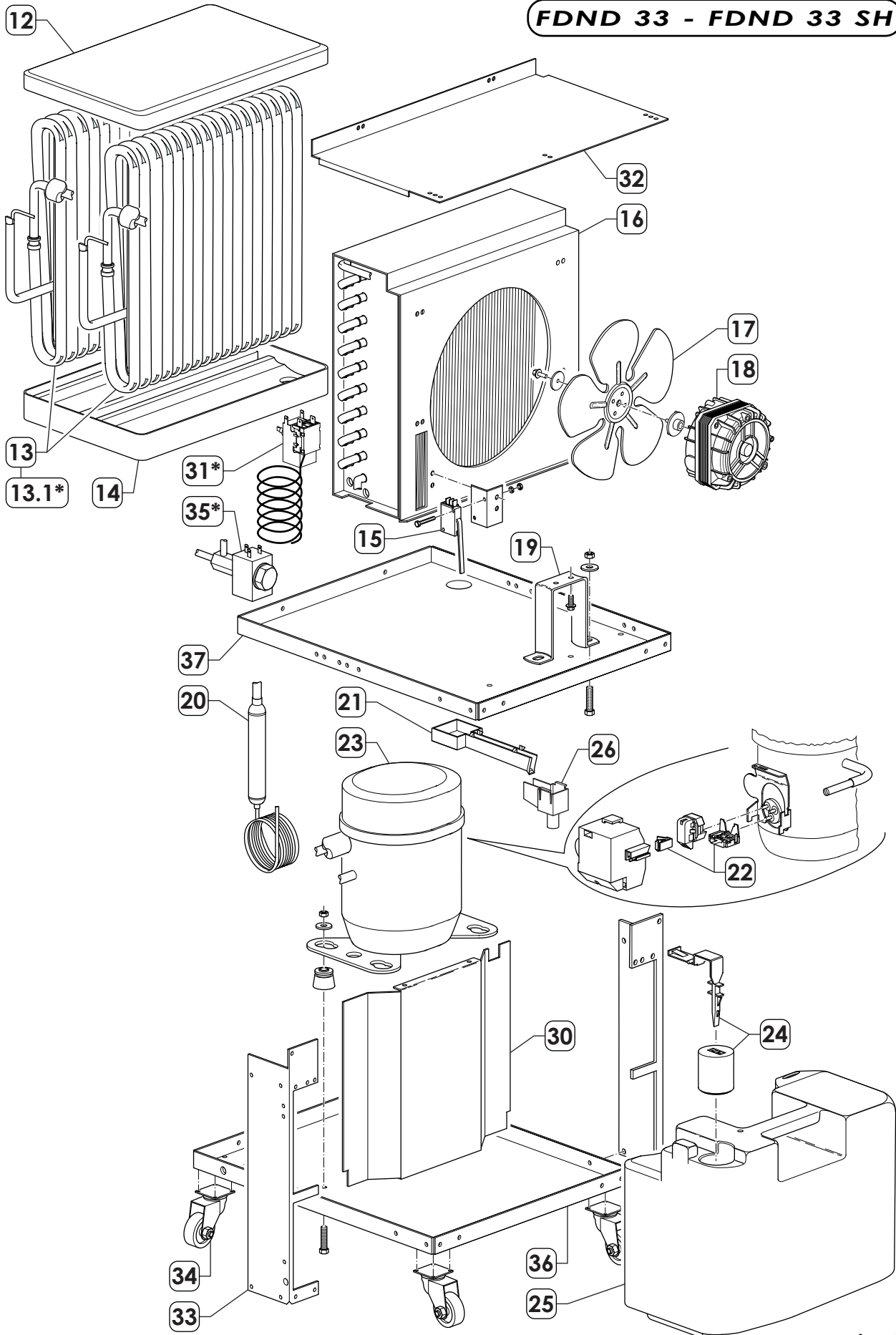

Fig. 3

MODULO D'ORDINE RICAMBI

MODELLO MODEL	Posizione n° Position n°	Descrizione Description	Quantità Quantity

Esempio

FD26	14	Motore ventilatore	1
FD36S	12	Condensatore	1

Example:

FD26	14	Motorfan	1
FD36S	12	Condenser	1