

## Spare Parts Catalogue

# E4000

Power systems | Generating sets

Valid for machine code: PA292SHI000

Revision: 0 (10/2006)

Copyright 2016 Pramac Group, All Rights Reserved.

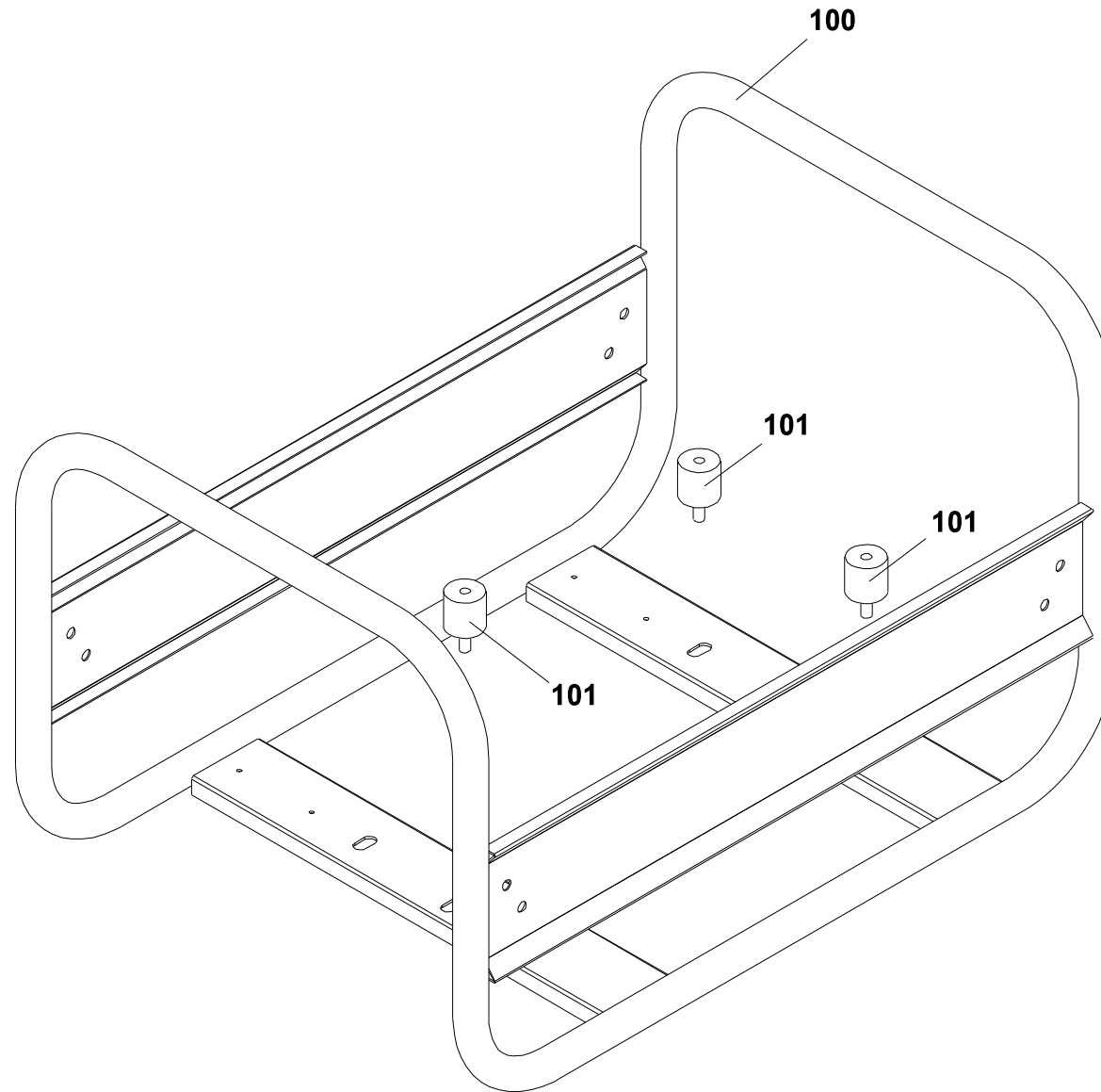

Position	Part Number	Description	Notes
100	▲ VA40005051-PRAMACB	Frame Painted E3200-4000	Valid for products manufactured from 18/09/2014
	▲ VA40019004-PRAMACB	Frame Pram23 Vert	Valid for products manufactured from 22/11/2011 to 18/09/2014
	▲ VA40019001-PRAMACB	Painted Complete Frame E - Hg Pramac Green Orange Peel Texture	Valid for products manufactured until 22/11/2011
101	G052113	Cylindric Silent-block Mf-30x30-m8x15-m8-45	-

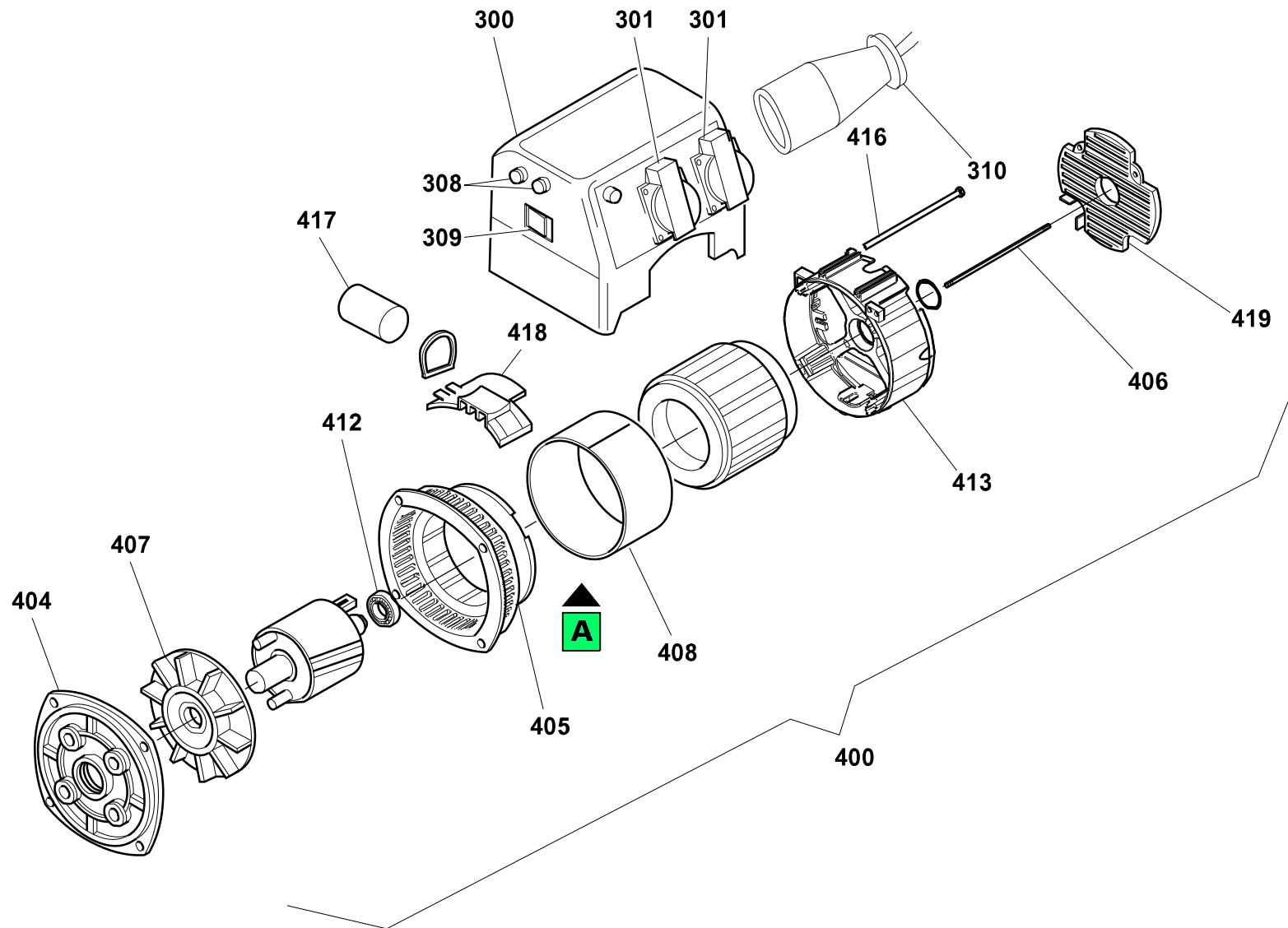

Position	Part Number	Description	Notes
300	PAN1GGA000013	Cover 802 Punched For 2schuko/cee + 2breaker .+comm.+b.c.	-
301	G071131	Socket Subassembly, Power Supply	-
302	G071131	Socket Subassembly, Power Supply	-
308	G075531	Thermal Circuit Breaker 10a 240v	-
310	G71230	Flying Plug Schuko	-
400	ANS3500CA0A2AY	Alternator Es80e 3.5/115/230/50/3000 J609a - Cover Es 80 Cablato 2 Schuko Protette + T 10a + Prot x Breaker	-
404	G69687	Motor Coupling Flange Es80j609c19	-
405	G69688	Front Plate Es80	-
406	G69685	Tension Rod Zinc Plated M8-5/16"24unf Es80a C19	-
407	PAN1VGA00002	Fan	-
408	PAN3APPL0013N	Black Enclosing Band For Es80 C/d	-
413	G69693	Rear Plate Es80	-
416	PAN7ZUN08205	Alternator Rod Es80e 3.5kva	-
417	G70698	Capacitor 18mf	-
418	G69698	Capacitor Support Bracket 1mvv002	-
419	G69686	Rear Cover 1gga00002	-

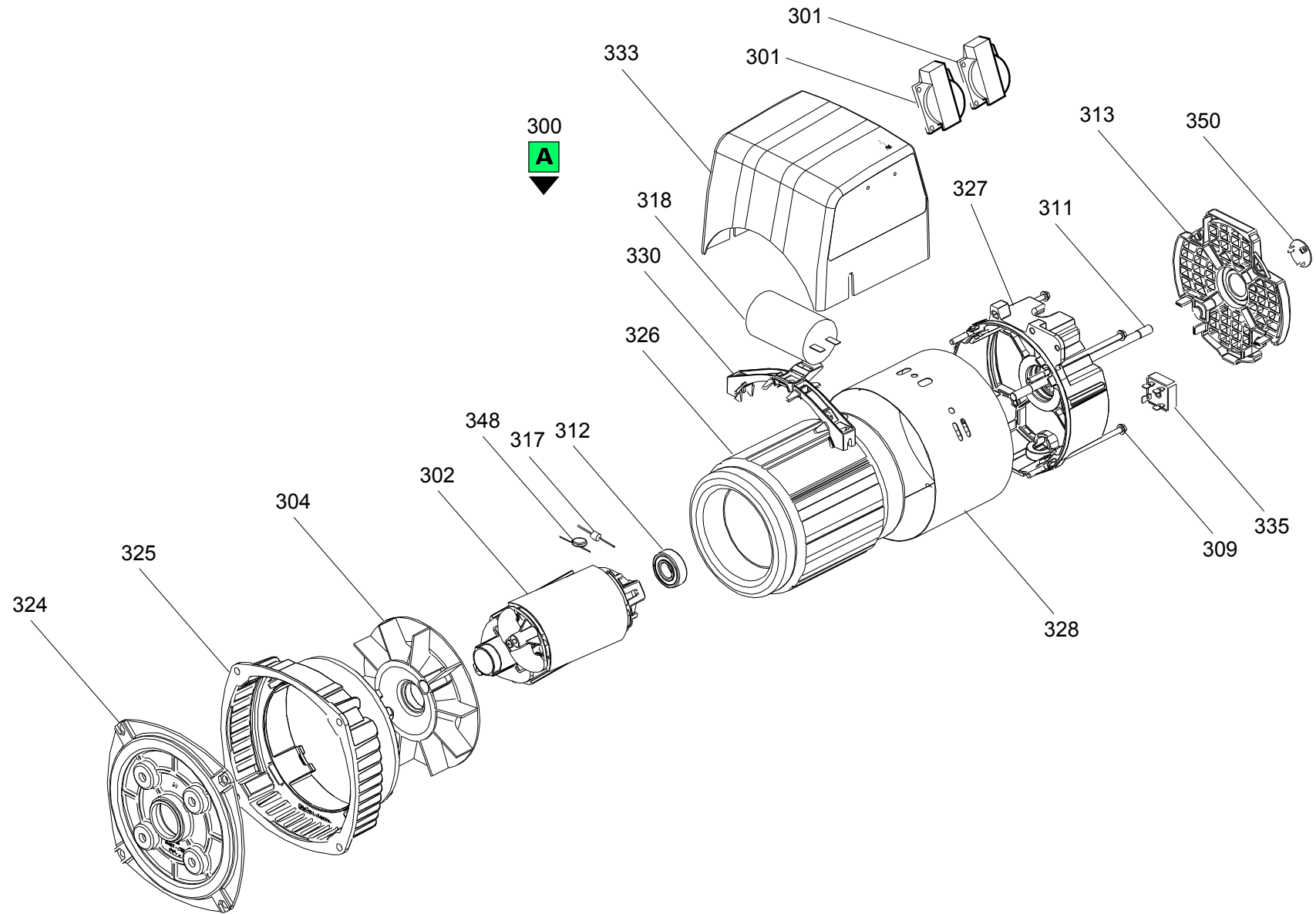

Position	Part Number	Description	Notes
300	ANS3500CA0A2AW	Alternator K80e 3.5/230/50/3000 J609a - Cover K80 Wired 2 Schuko Prot. + T 10a + Prot x Breaker 1,5mmq - Nsm	-
301	G071131	Socket Subassembly, Power Supply	-
304	PAN1VGA00002	Fan	-
309	PAN7VTE05145	Screws For Bracket Fixing	-
311	PAN7ZUN08205	Alternator Rod Es80e 3.5kva	-
312	G010408	Bearing 6202 2rs (15-35-11)	-
313	PAN1GGA00008	No Drive End Grid	-
317	G69621	Battery Charger Diode 6a - 1200v	-
318	G70698	Capacitor 18mf	-
324	PAN3FLA1011	Coupl. Flange J609a C19	-
325	PAN3SLA00003	Drive End Bracket	-
327	PAN3SLA00004	No Drive End Bracket	-
328	PAN3APPL0016	Enclosing Band	-
330	PAN1MVB004	Capacitor Support	-
333	PAN1GGA000940	Cover K80e 2	-
	PAN98ST12Z	Coperchio Superiore Con 2 Schuko + T 12a Con Prot.	-
335	PANKPD25A02	Ponte Raddrizzatore Monofase 15°-200v	-
348	PANKVZ12A420	Varistor	-
350	PAN7PRTS0232	Plastic Plug Es80	-

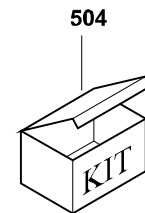
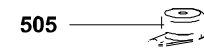
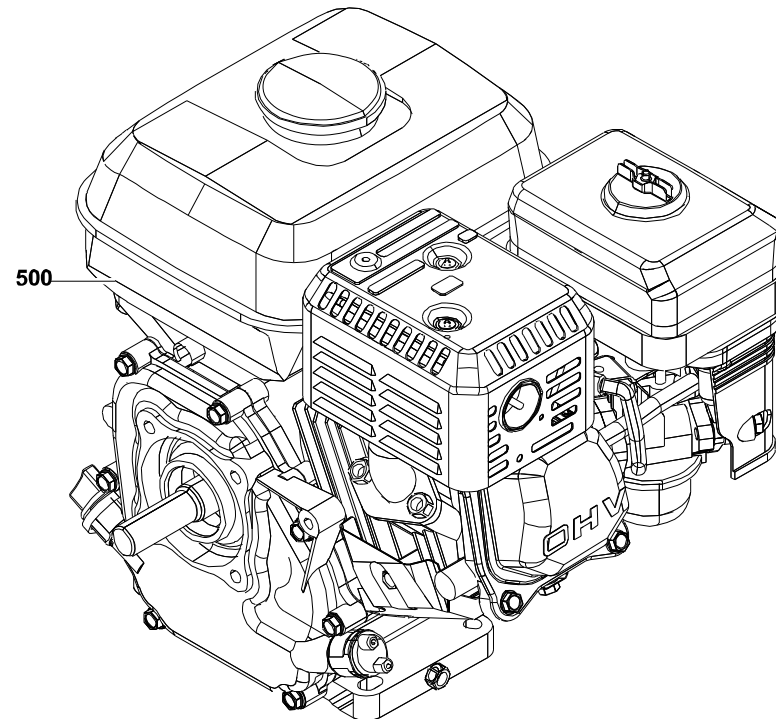
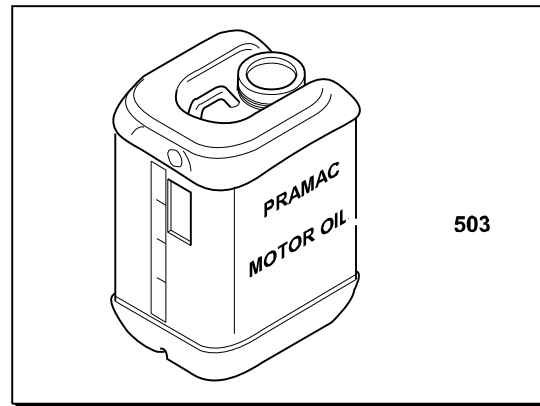
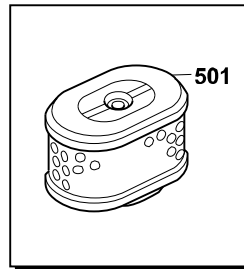
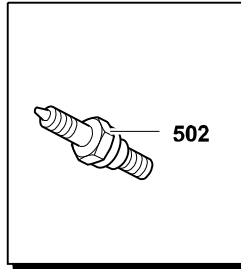



Position	Part Number	Description	Notes
500	▲ EHA65BA1FZ	Engine Honda Gx200h Vsp Air_3000_mech_j609a-_handstart__ver/sp:	Valid for products manufactured from 11/12/2013
	▲ EHA65BAC8Y	Engine Honda Gx200t2 Vsp Air_3000_mech_j609a-_handstart__ver/sp:	Valid for products manufactured from 03/01/2013 to 11/12/2013
	▲ EHA65BAC8Z	Engine Honda Gx200t Vsp Air_3000_mech_j609a-_handstart__ver/sp:	Valid for products manufactured from 19/03/2007 to 03/01/2013
	▲ EHA65BA10Z	Engine Honda Gx200t Vx4 Air_3000_mech_j609a-_handstart__ver/sp:	Valid for products manufactured from 26/09/2006 to 19/03/2007
	▲ EHA65BA32Z	Engine Honda Gx200ut Vsd7 Air_3000_mech_j609a-_handstart__ver/sp:	Valid for products manufactured until 26/09/2006
501	PEH17210-ZE1-505	Air Filter Element	-
502	PEH98079-56876	Spark Plug	-
503	P3KI00299	Kit Pramac Power	-
504	P3KI00005	Maintenance Kit E4000-e3600-e3200-hg4000 Pw150-pw1500	-