

Planning

Space requirements in the cabinet

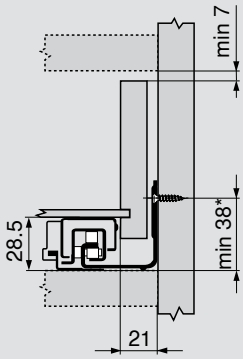

\* + 1 mm if cabinet profile is installed before cabinet is assembled

Drawer/inner drawer

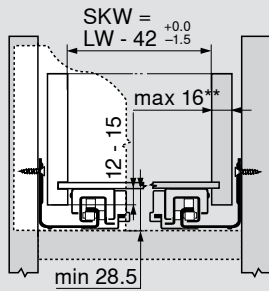

\*\* Limited side adjustment for a drawer side panel thickness of 16 mm, but with full tolerance utilisation of the SKW

Drawer

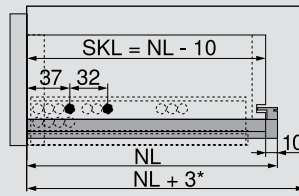

\* Additional + 12 mm with side stabilisation

Inner drawer

With BLUMOTION S

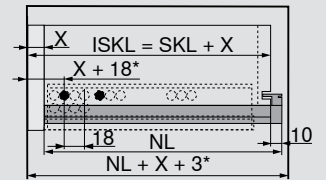

\* Additional + 3 mm with depth adjustment

with TIP-ON

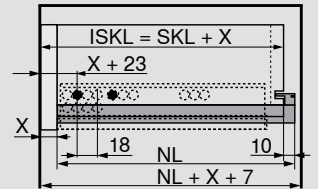

Cabinet profile screw position – 40 kg

NL (mm)

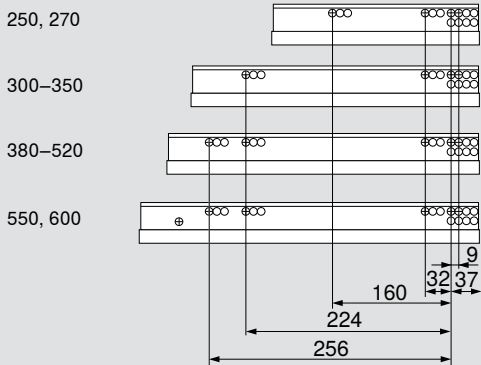

Cabinet profile screw position – 60 kg

NL (mm)

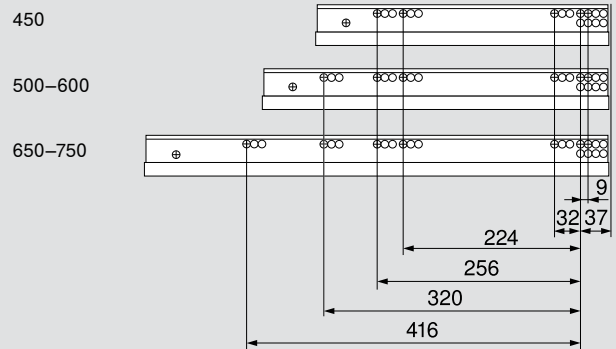

ISKL Inner drawer length  
LW Internal cabinet width

NL Nominal length  
SKL Drawer length

SKW Internal drawer width  
X Front thickness

## Planning

### Space requirements in the cabinet

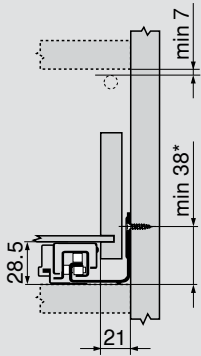

\* + 1 mm if cabinet profile is installed before cabinet is assembled

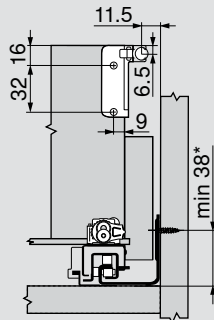

\* + 1 mm if cabinet profile is installed before cabinet is assembled

### High fronted pull-out

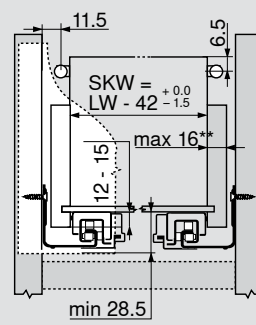

\*\* Limited side adjustment for a drawer side panel thickness of 16 mm, but with full tolerance utilisation of the SKW

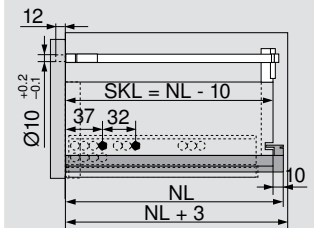

### Cabinet profile screw position – 40 kg

NL (mm)

400–520

550, 600

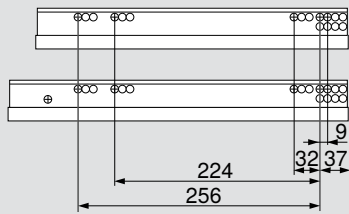

### Cabinet profile screw position – 60 kg

NL (mm)

450

500–600

650

