

TR 232 S

SPARE PART LIST



NORTON
SAINT-GOBAIN®

clipper®

TYPE :

S = Spare part

W = Wear part

NA = Not Available

The kits of spare parts contain all screws and bolts and the components referring itself to it.

Screws and bolts is component of standard assembly, which you can easily find at all the retailers of standard components of assembly.

All the components of standard assembly are of a quality grade 8.8.

We recommend not to use a quality grade lower than 8.8 for all the standard components of assembly.

The parts of replacements CLIPPER must always be used.

The wearing parts have one lifetime limited in time because of a normal use of the machine. This lifetime strongly depends on the intensity of use of the machine. The wearing parts are to be maintained, use and to change if necessary according to the indications of manufacturing.

A wear because of normal use of the machine does not give the right to a warranty.

The components NA (Not Available) are not available in spare part.

TYPE :

S = Pièce de rechange

W = Pièce d'usure

NA = Non disponible

Les kits de pièces détachées contiennent toute la visserie et les composants s'y rapportant.

La visserie est un composant d'assemblage standard, que vous pouvez facilement trouver chez tous les détaillants de composants d'assemblage standards.

Tous les composants d'assemblage standard sont d'une classe de qualité 8.8.

Nous recommandons de ne pas utiliser une classe de qualité inférieure à 8.8 pour tous les composants d'assemblage standards.

Les pièces de remplacements CLIPPER doivent toujours être utilisées.

Les pièces d'usure ont une durée de vie limitée dans le temps du fait d'une utilisation normale de la machine. Cette durée de vie dépend fortement de l'intensité d'utilisation de la machine. Les pièces d'usure sont à entretenir, à utiliser et le cas échéant à changer selon les indications du fabricant.

Une usure du fait de l'utilisation normale de la machine ne donne pas droit à une garantie.

Les composants NA (Not Available) ne sont pas disponibles en pièce de rechange.

TYP:

S = Ersatzteile

W = Verschleißteile

NA = Nicht verfügbar

Die Sätze von Ersatzteilen sich enthalten die ganze Schraubenfabrik und die darauf beziehenden Bestandteile.

Die Schraubenfabrik ist ein Standardzusammensetzungsbestandteil, den Sie leicht bei allen Standardeinzelhändler von Zusammensetzungsbestandteilen finden können.

Alle Standardzusammensetzungsbestandteile sind von einer Qualitätsklasse 8.8.

Wir empfehlen, keine Qualitätsklasse unter 8.8 für alle Standardzusammensetzungsbestandteile zu benutzen.

Die CLIPPER-Austauschstücke müssen immer benutzt werden.

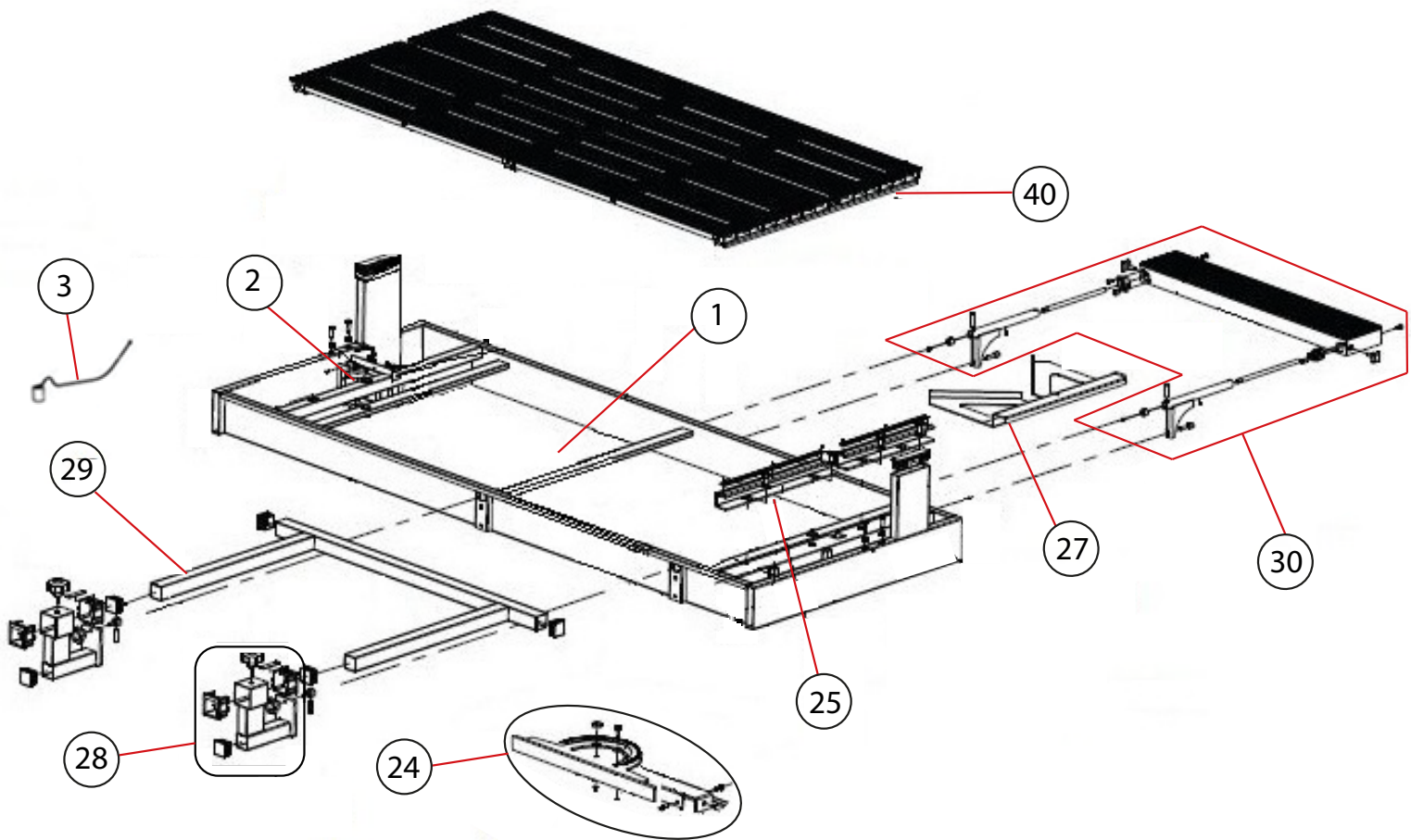
Die Abnutzungsstücke haben eine Lebensdauer, die in der Zeit wegen einer normalen Benutzung der Maschine begrenzt ist. Diese Lebensdauer hängt stark von der Intensität der Benutzung der Maschine ab.

Die Abnutzungsstücke sind zu unterhalten, und gegebenenfalls zu benutzen nach herstellenden Hinweisen zu wechseln. Eine Abnutzung wegen der normalen Benutzung der Maschine gibt einer Garantie kein Recht.

Die Bestandteile NA (Not Available), sind in Ersatzteil nicht verfügbar.

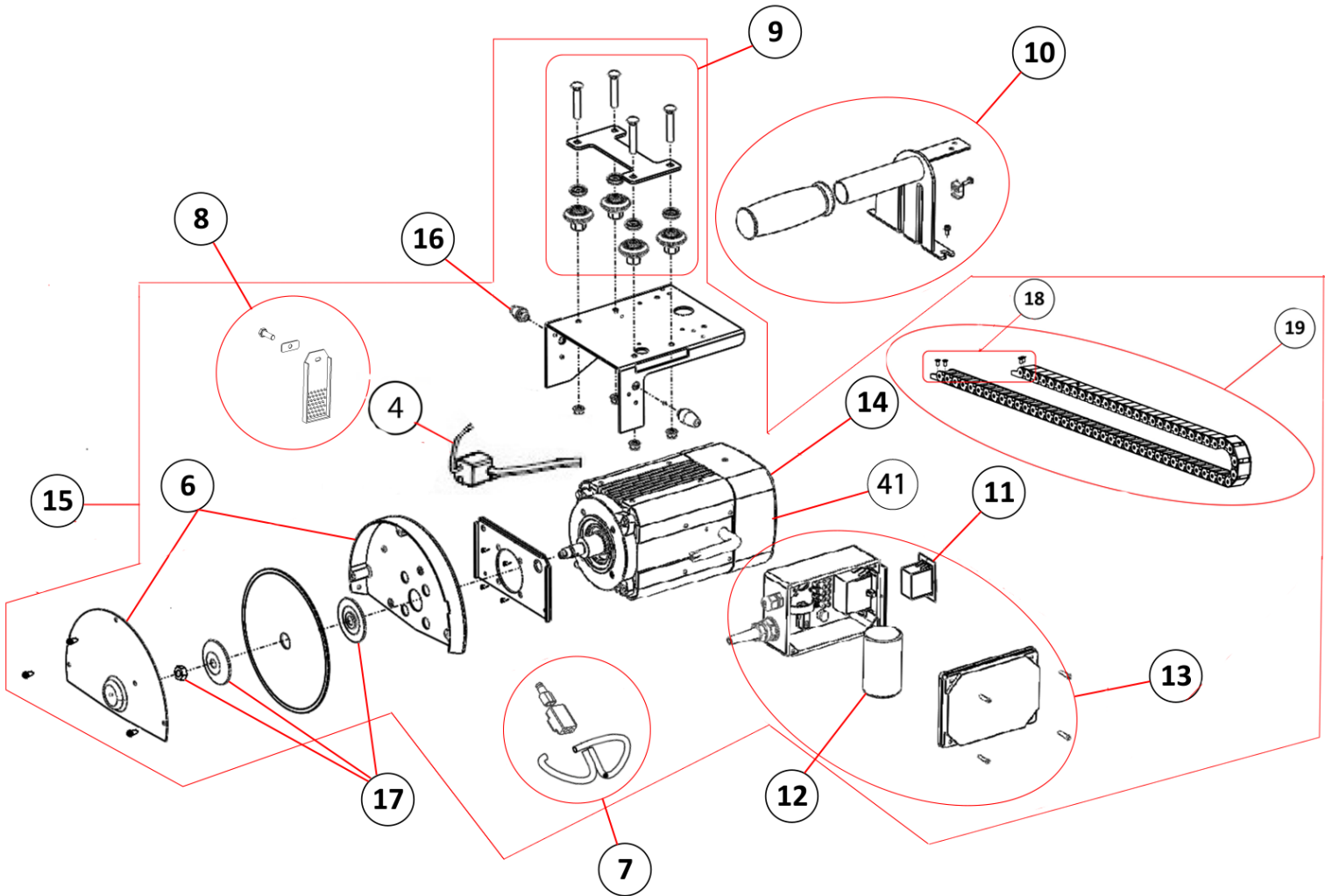


Table / Table / Tisch



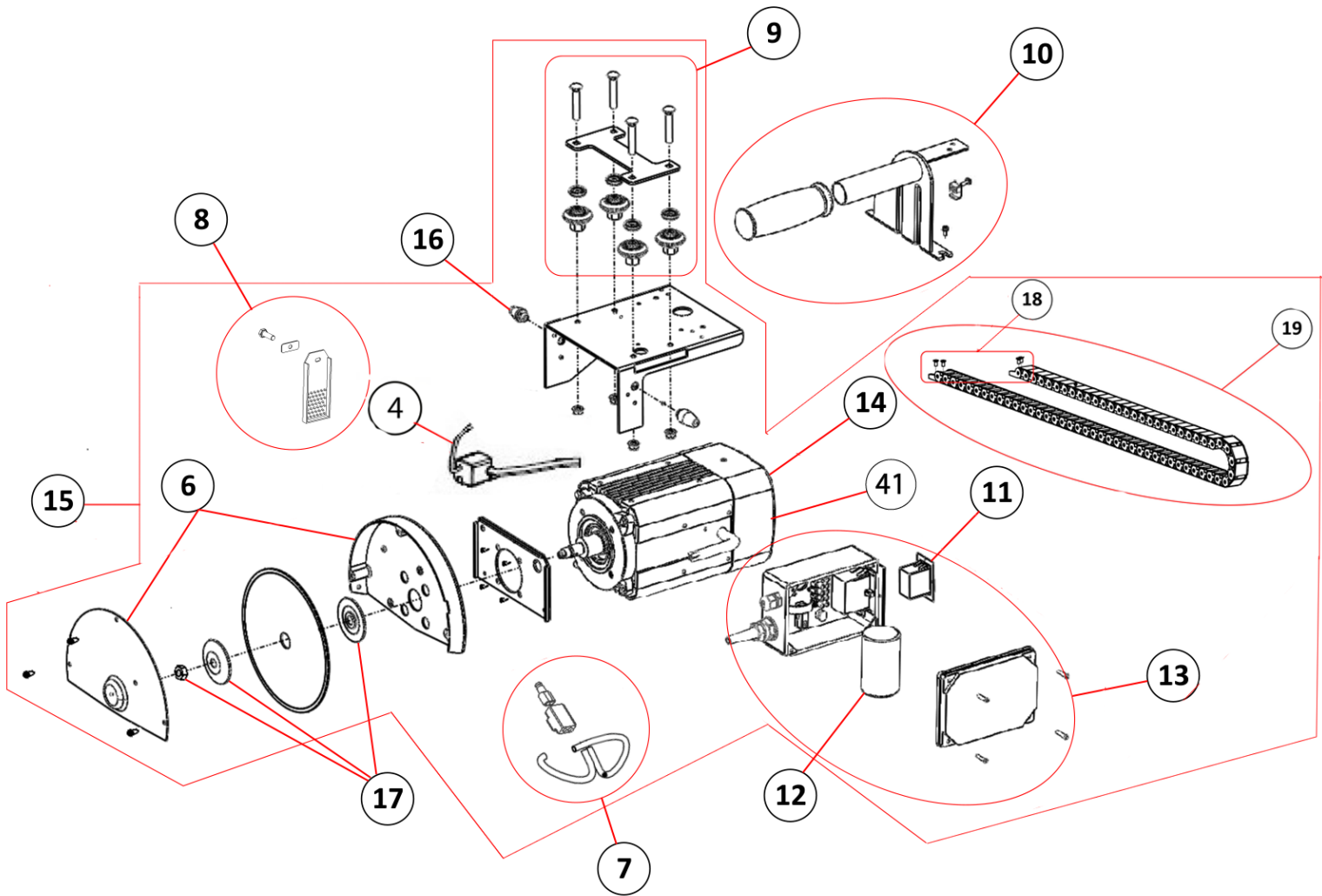
POS.	DESCRIPTION	DESCRIPTION	BESCHREIBUNG	QTY	REF	TYPE
1	Water tank kit	Kit réservoir d'eau	Wasserbehälter kit	1	510134567	S
	Water tank	Réservoir d'eau	Wasserbehälter	1		
	screw DIN 933 - M6x20	vis DIN 933 - M6x20	Schraube DIN 933 - M6x20	5		
	washer DIN 125 - A6,4	rondelle DIN 125 - A6,4	Scheibe DIN 125 - A6,4	5		
	nut DIN 934 - M6	ÉCROU DIN 934 - M6	Mutter DIN 934 - M6	5		
	Clipper® Sticker	Autocollant Clipper®	Clipper® Sticker	2		
	Pressing mats	Element de pression	Druckelement	3		
	nut ISO4032 - M12	ÉCROU ISO4032 - M12	Mutter ISO4032 - M12	3		
2	Water filter kit	Kit filtre de bac à eau	Filter des Wasserbehälter kit	1	510111581	S
	Net plate	Plaque de serrage du filtre	Klemmplatte des Filters	1		
	Net	Filtre	Filter	1		
	screw DIN 965 - M3x10	vis DIN 965 - M3x10	Schraube DIN 965 - M3x10	6		
	nut DIN 934 - M3	ÉCROU DIN 934 - M3	Mutter DIN 934 - M3	6		
3	Water plug	Bouchon de bac à eau	Vollständige Wasserbehälter Stöpsel	1	510100986	S
	Plug	Bouchon	Stöpsel	1		
	Chain	Chaîne	Kette	1		
4	Water pump 230V	Pompe à eau 230V	Wasserpumpe 230V	1	310365204	W
	Water pump 115V	Pompe à eau 115V	Wasserpumpe 115V	1	510126238	W
24	Angular Cutting guide assy..	Guide de coupe angulaire complet	Schnittführung, kompl.	1	510126208	S
	Angle plate	Plaque d'angle	Winkelplatte	1		
	Angle ruler	Graduation angulaire	Eckige Maßteile	1		
	Fixing ring	Anneau de fixation	Haltering	1		
	Cap	Bouchon	Stöpsel	1		
	Angle ruler part	Pièce de la règle d'angle	Stück der Winkelregel	1		
	screw ISO4017 - M6x16	vis ISO4017 - M6x16	Schraube ISO4017 - M6x16	3		
	washer ISO7093 - M6	rondelle ISO7093 - M6	Scheibe ISO7093 - M6	1		
	nut ISO4032 - M6	ecrou ISO4032 - M6	Mutter ISO4032 - M6	2		
	screw DIN316 - M8x60	vis DIN316 - M8x60	Schraube DIN316 - M8x60	1		
	nut ISO10511 - M8	ecrou ISO10511 - M8	Mutter ISO10511 - M8	1		
	Sliding mat	Elément de blocage	Blockierelement	1		
	Blocking ring M8	Anneau de blocage M8	Blockierring M8	1		
25	Material stop assy.	Butée de matériaux complète	Material-Anschlag, kompl.	1	510126209	S
	screw DIN 933 – M8X16	vis DIN 933 – M8X16	Schraube DIN 933 – M8X16	4		
	washer DIN 125 – Ø8,4	rondelle DIN 125 – Ø8,4	Scheibe DIN 125 – Ø8,4	4		
	Material stop left	Butée gauche	Anschlag links	1		
	Material stop right	Butée droite	Anschlag rechts	1		
27	"V" guide	Guide en "V"	Führer aus „V“	1	510094410	S
28	Long fence frame kit	Kit support de grande butée	Langer Zaunrahmen kit	1	510126211	S
	Long fence frame	Support de grande butée	Langer Zaunrahmen	2		
	Plastic caps	Bouchons plastique	Plastikkappen	2		
	Protecting mat	Eléments de protection	Schützende Matte	4		
	Protecting plate	Plaque de protection	Schützende Platte	2		
	Locking screw	vis de blocage	Feststellschraube	2		
	SPINDLE - M6x27	AXE - M6x27	ACHSE - M6x27	2		
	Knob	Bouton	Griff	2		
29	Lateral guide of cut	Guide de coupe latéral	Längsschnittführung	1	510126212	S
	Long fence	Grande butée	Langer Zaun	1		
	Plastic caps	Bouchons plastique	Plastikkappen	4		
30	Table extension assy	Rallonge de table assy	Tafelverlängerung assy	1	310365223	S
	Table extension	Rallonge de table	Tafelverlängerung	1		
	Extension pole	Barre d'extension	Ausdehnungsstange	2		
	Supporting frame	Cadre support	Trägerrahmen	2		
	SPINDLE - M6x27	AXE - M6x27	ACHSE - M6x27	2		
	screw DIN 965 - M3X6	vis DIN 965 - M3X6	Schraube DIN 965 - M3X6	2		
	Adjusting knob	Bouton réglable	Regulierbarer Knopf	2		
	Base for extending	Base de rallonge	Verlängerungsbasis	2		
	screw ISO7051 - ST3,5x16	vis ISO7051 - ST3,5x16	Schraube ISO7051 - ST3,5x16	4		
	Star knob	Bouton en étoile	Knopf in Stern	2		
	screw DIN 965 - M5x10	vis DIN 965 - M5x10	Schraube DIN 965 - M5x10	2		
40	Table assy.	Table complète	Tafel	1	510100987	S
	Table	Table	Tafel	1		
	screw DIN 965 – M4X10	VIS DIN 965 – M4X10	Schraube DIN 965 – M4X10	23		
	screw DIN 965 – M5X10	VIS DIN 965 – M5X10	Schraube DIN 965 – M5X10	12		

Cutting head / Tête de coupe / Schüsselkopf



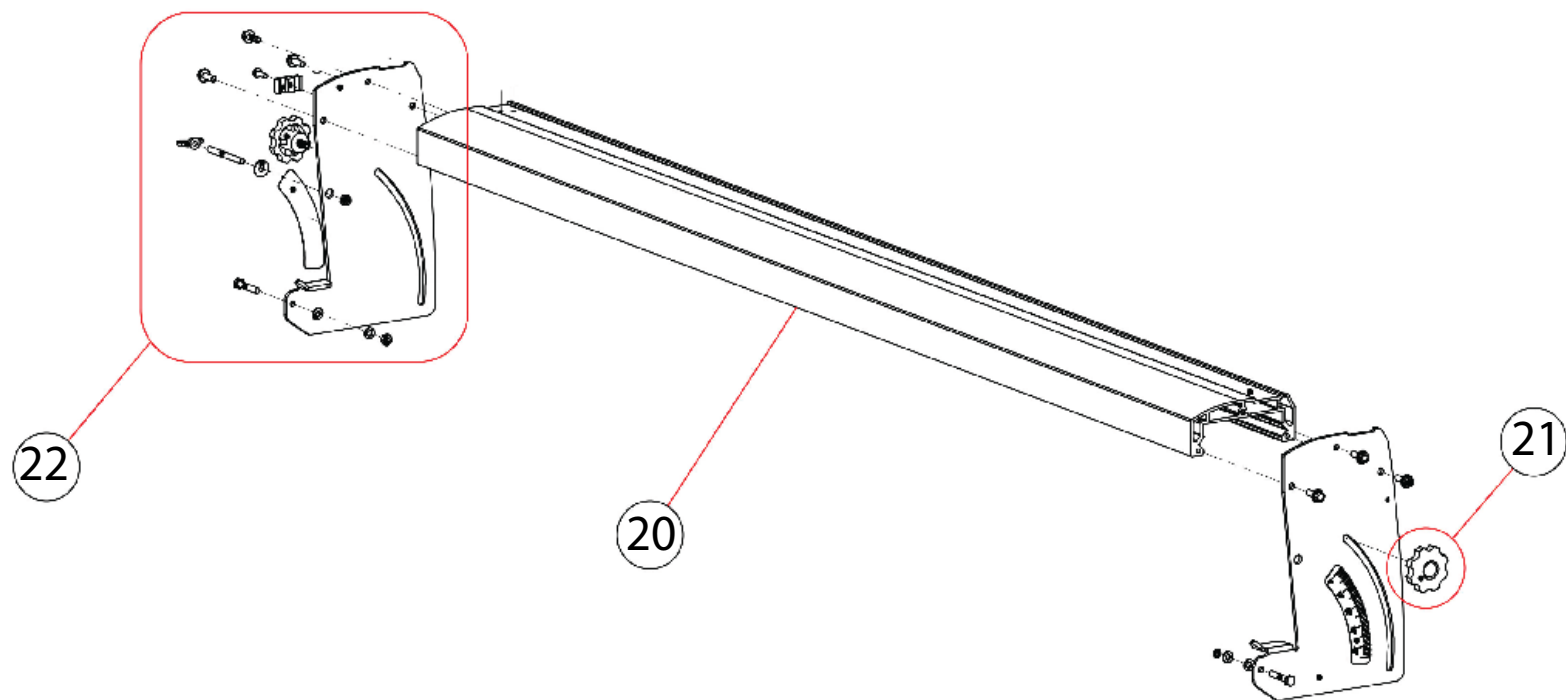
POS.	DESCRIPTION	DESCRIPTION	BESCHREIBUNG	QTY	REF	TYPE
6	Blade guard kit	Kit carter de lame	Klingengehäuse kit	1	510136508	S
	screw DIN 966 - M5x20	vis DIN 7985 - M5x20	Schraube DIN 966 - M5x20	3		
	washer DIN 125 - M5	rondelle DIN 125 - M5	Scheibe DIN 125 - M5	3		
	screw DIN 966 - M5x12	vis DIN 7985 - M5X12	Schraube DIN 966 - M5X12	3		
	Guard cover	Face avant carter de lame	Avant Seite Klingengehäuse	1		
	Fixed guard cover	Carter de lame fixe	Festes Klingengehäuse	1		
7	Watering kit	Kit Arrosage	Bewässerung Kit	1	510094446	S
	7mm water tube	Tube 7mm	7mm röhre	2		
	Tube guider	Guide de tube	Röhrenführer	1		
	Tube connector	Connecteur	Verbindung	1		
8	Splash guard kit	Kit Bavette	Landeklappe kit	1	510126175	W
	Splash guard	Bavette	Spritzschutzlappen	1		
	screw DIN 933 - M6x16	vis DIN 933 - M6x16	Schraube DIN 933 - M6x16	1		
	nut DIN315 - M6	écrou DIN315 - M6	Mutter DIN315 - M6	1		
	Plate	Plaque	Platte	1		
9	Guiding wheels assy (SET OF 4)	Ensemble de roulette de guidage (jeu de 4)	Rollenführungen, kompl. (Satz von 4)	1	510134481	W
	Eccentric wheels	Roulette excentrique	Exzenterrädern	2		
	Bearing	Roulement	Rollen	4		
	screw M8x60	vis M8x60	Schraube M6x10	4		
	Fixe wheels	Roulettes fixe	fixe Räder	2		
	Wheels support plate	Plaque support roulettes	Räder Platteträger	1		
	nut ISO10511 - M8	écrou ISO10511 - M8	Mutter ISO10511 - M8	4		
10	Handle assy. Cutting head	Poignée tête de coupe complète	Handgriff, kompl.	1	510134544	S
	Screw DIN 7985-H -M5X25	Vis DIN 7985-H -M5X25	Schraube DIN 7985 - H- M5X25	2		
	Washer DIN 125 -Ø5,3	Rondelle DIN 125 -Ø5,3	Scheibe DIN 125 - Ø5,3	2		
	Handle Cutting head	Poignée tête de coupe	Handgriff	1		
	Rubber handle	Poignée caoutchouc	Gummigriff	1		
11	Switch 230V	Interrupteur 230V	Schalter 230V	1	310340138	S
	Switch 115V	Interrupteur 115V	Schalter 115V	1	510127054	S
	screw ISO7051 - ST2,6x8	vis ISO7051 - ST2,6x8	Schraube ISO7051 - ST2,6x8	4		
	Pressing plate	Plaque de pression	Druckplatte	1		
	Water proof rubber protection	Protection en caoutchouc étanche	Wasserdichter Gummischutz	1		
	Switch	Commutateur	Schalter	1		
12	Capacitor 230V	Condensateur 230V	Kondensator 230V	1	510126177	S
	Capacitor 115V	Condensateur 115V	Kondensator 115V	1	510126178	S
13	Connecting box assy 230V	Boitier de raccordement complet 230V	E-Anschlußkasten, kompl.230V	1	510100960	S
	Connecting box assy 115V	Boitier de raccordement complet 115V	E-Anschlußkasten, kompl.115V	1	510126237	S
	Switch box cover	Couvercle du boitier	Deckel des Gehäuses	1		
	Rubber seal	Joint caoutchouc	Verbunden Gummi	1		
	Switch box	Boitier	Gehäuse	1		
	screw ISO7051 - ST2,9x14	vis ISO7051 - ST2,9x14	Schraube ISO7051 - ST2,9x14	4		
	Capacitor	Condensateur	Kondensator	1		
	Capacitor clamp	Blocage condensateur	Condensateur Blockieren	1		
	screw ISO7051 - ST3,5x10	vis ISO7051 - ST3,5x10	Schraube ISO7051 - ST3,5x10	1		
	Rubber blocker	Bloqueur caoutchouc	GummiBlocker	2		
	Terminal block	Domino	Domino	1		
	Pressing board	Element de pression	Druckelement	1		
	Inner nuts	Écrous interne	Interne Muttern	1		
	Big iner nut	Grand écrou interne	Große interne Mutter	1		
	screw ISO7051 - ST3,5x16	vis ISO7051 - ST3,5x16	Schraube ISO7051 - ST3,5x16	2		
	screw ISO7046 - M5x12	vis ISO7046 - M5x12	Schraube ISO7046 - M5x12	4		
	Switch	Commutateur	Schalter	1		
	Water proof rubber protection	Protection en caoutchouc étanche	Wasserdichter Gummischutz	1		
	Pressing plate	Plaque de pression	Druckplatte	1		
	screw ISO7051 - ST2,6x8	vis ISO7051 - ST2,6x8	Schraube ISO7051 - ST2,6x8	4		
	Seal	Joint	Verbunden	1		
	Connector B	Connecteur B	Verbindung B	1		
	Out nuts A	Écrous A	Mutter A	1		
	Connector A	Connecteur A	Verbindung A	1		
	Big nuts	Grands écrous	Große Muttern	1		
	Protecting sets	Ensembles protecteurs	Schutzgesamtheit	1		

Cutting head / Tête de coupe / Schüsselkopf



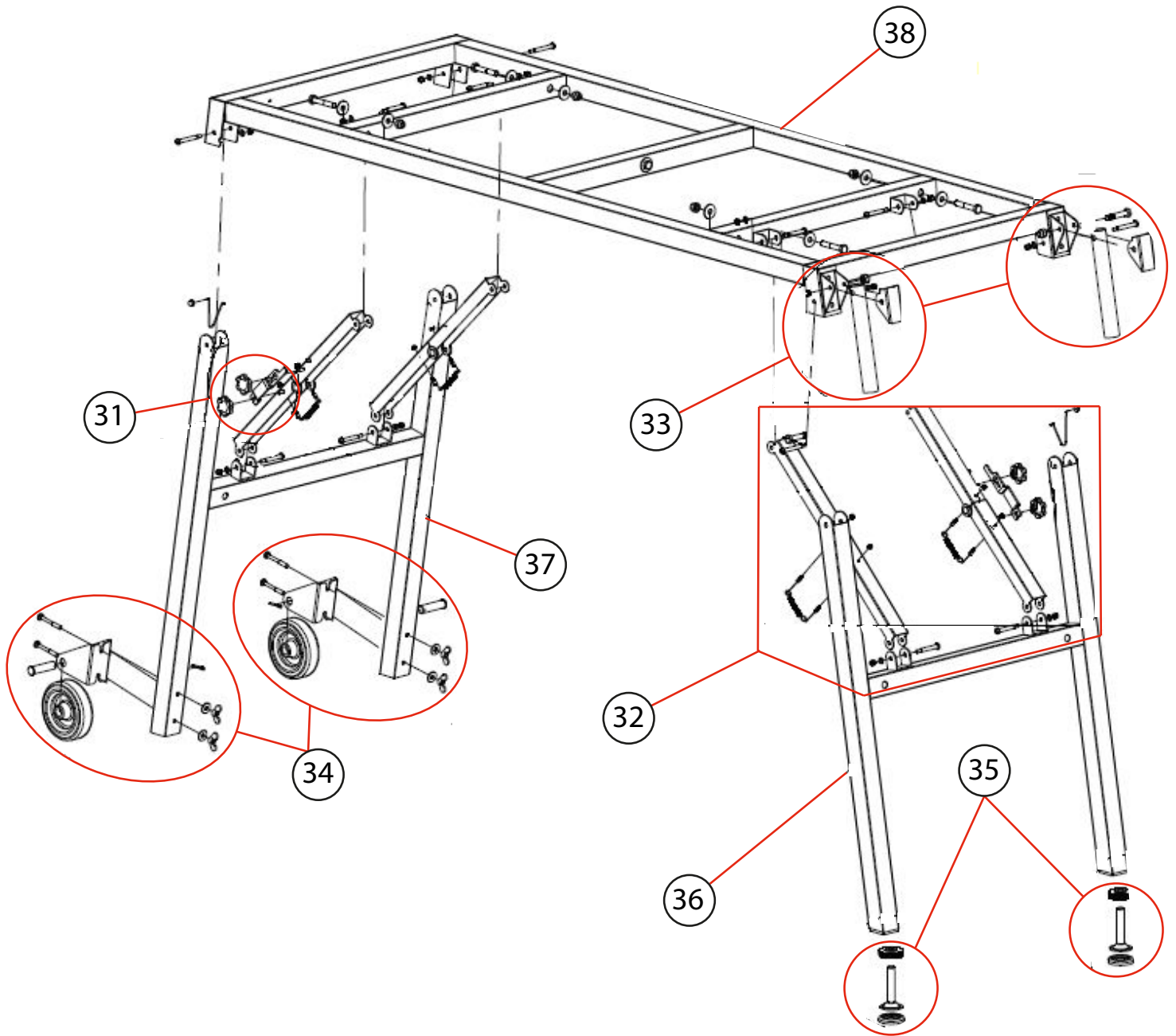
POS.	DESCRIPTION	DESCRIPTION	BESCHREIBUNG	QTY	REF	TYPE
14	Motor 230V	Moteur électrique 230V	E-Motor 230V	1	510100961	S
	Motor 115V	Moteur électrique 115V	E-Motor 115V	1	510126201	S
15	Cutting head assy. 230V	Tête de coupe complète 230V	Schneidkopf, kompl. 230V	1	510140067	S
	Cutting head assy. 115V	Tête de coupe complète 115V	Schneidkopf, kompl. 115V	1	510140068	
	Electric motor 230V	Moteur électrique 230V	E-Motor 230V	1		
	Electric motor 115V	Moteur électrique 115V	E-Motor 115V	1		
	Motor support	Support moteur	Motoranbauplatte	1		
	screw M8x16	vis M8x16	Schraube M8x16	4		
	washer DIN128 - M8	rondelle DIN128 - M8	Scheibe DIN128 - M8	4		
	washer ISO7089 - M8	rondelle ISO7089 - M8	Scheibe ISO7089 - M8	4		
	Rubber stop	Butée caoutchouc	Gummipuffer	2		
	screw ISO7985 - M4x10	vis ISO7985 - M4x10	Schraube ISO7985 - M4x10	2		
	Pressing plate	Plaque de pression	Druckplatte	1		
	Tube clip	Blocage de tube	Röhrenblockieren	1		
	screw ISO7985 - M5x10	vis ISO7985 - M5x10	Schraube ISO7985 - M5x10	1		
	nut ISO10511 - M5	ecrou ISO10511 - M5	Mutter ISO10511 - M5	1		
	screw DIN 966 - M5x20	vis DIN 966 - M5x20	Schraube DIN 966 - M5x20	3		
	washer DIN 125 - M5	rondelle DIN 125 - M5	Scheibe DIN 125 - M5	3		
	screw DIN 966 - M5x12	vis DIN 966 - M5X12	Schraube DIN 966 - M5X12	3		
	Guard cover	Face avant carter de lame	Avant Seite Klingengehäuse	1		
	Fixed guard cover	Carter de lame fixe	Festes Klingengehäuse	1		
	Mobile flange	Flasque mobile	Loser Flansch	1		
	Fixed flange	Flasque fixe	Fester Flansch	1		
	nut M12 (left threaded)	ecrou M12 avec filet à gauche	Mutter M12 mit Linksgewinde	1		
	Splash guard	Bavette	Spritzschutzlappen	1		
	screw DIN 933 - M6x16	vis DIN 933 - M6x16	Schraube DIN 933 - M6x16	1		
	nut DIN315 - M6	ecrou DIN315 - M6	Mutter DIN315 - M6	1		
	Plate	Plaque	Platte	1		
	Watering kit	Kit Arrosage	Bewässerung Kit	1		
	7mm water tube	Tube 7mm	7mm röhre	2		
	Tube guider	Guide de tube	Röhrenführer	1		
	Tube connector	Connecteur	Verbindung	1		
	Water pump 230V	Pompe à eau 230V	Wasserpumpe 230V	1		
	Water pump 115V	Pompe à eau 115V	Wasserpumpe 115V	1		
	Plastic chain end kit	Kit embout de chemin de câble	Plastikkettenende kit	1		
	screw DIN 965 - M5x10	vis DIN 965 - M5x10	schraube DIN 965 - M5x10	4		
	Cable Support end	Embout chemin de câble	Endstücke Kabelbahn	2		
	Cable support kit	Kit chemin de câble (incl. 18)	Kabelhalterzus kit	1		
	screw DIN 7985 - M5X6	vis DIN 7985 - M5X6	schraube DIN 7985 - M5X6	4		
	screw DIN 965 - M5X10	vis DIN 965 - M5X10	schraube DIN 965 - M5X10	1		
	Cable Support end	Embout chemin de câble	Endstücke Kabelbahn	2		
	Cable support fixing	Fixation de chemin de cable	Kabeltrag-Befestigungs	1		
	Cable support	Chemin de câble	Kabelbahn	1		
16	Rubber stop	Butée caoutchouc	Gummipuffer	1	510126242	S
	Front rubber stop (40mm)	Butée avant (40mm)	Vorderer gummipuffer (40mm)	1		
	Back rubber stop (25mm)	Butée Arrière (25mm)	Hinterer gummipuffer (25mm)	1		
17	Flange + left hand threaded nut kit	Kit flasques + ecrou pas à gauche	Lagerschildes + Linksgewinde Mutter kit	1	510100973	S
	Mobile flange	Flasque mobile	Loser Flansch	1		
	Fixed flange	Flasque fixe	Fester Flansch	1		
	nut M12 (left threaded)	ecrou M12 avec filet à gauche	Mutter M12 mit Linksgewinde	1		
41	Motor fan cover	Capot ventilateur moteur	Motorlüfterabdeckung	1	310396720	S

Guiding rail / Rail de guidage / Führungsschiene



POS.	DESCRIPTION	DESCRIPTION	BESCHREIBUNG	QTY	REF	TYPE
18	Plastic chain end kit	Kit embout de chemin de câble	Plastikkettenende kit	1	510111414	S
	screw DIN 965 - M5x10	vis DIN 965 - M5x10	Schraube DIN 965 - M5x10	4		
	Cable Support end	Embout chemin de câble	Endstücke Kabelbahn	2		
19	Cable support kit	Kit chemin de câble (incl. 18)	Kabelhalterzus kit	1	310365200	S
	screw DIN 7985 - M5X6	vis DIN 7985 - M5X6	Schraube DIN 7985 - M5X6	4		
	screw DIN 965 - M5X10	vis DIN 965 - M5X10	Schraube DIN 965 - M5X10	1		
	Cable Support end	Embout chemin de câble	Endstücke Kabelbahn	2		
	Cable support fixing	Fixation de chemin de cable	Kabeltrag-Befestigungs	1		
	Cable support	Chemin de câble	Kabelbahn	1		
20	Guiding rail	Rail de guidage	Führungsschiene	1	510134554	W
	screw DIN 933 - M6x18	vis DIN 933 - M6x18	Schraube DIN 933 - M6x18	6		
	Guiding rail	Rail de guidage	Führungsschiene	1		
21	Securing knob kit	Kit bouton étoile à tige filetée	FeststellSchrauben	1	510126207	S
	Securing knob M8X 20	Bouton étoile à tige filetée M8X20	FeststellSchrauben M8X20	2		
	Securing knob M8X 50	Bouton étoile à tige filetée M8X50	FeststellSchrauben M8X50	1		
22	Rail support kit	Kit support rail de guidage	Schienenunterstützung kit	1	510134483	S
	Right rail support	Support rail de guidage droit	Rechter schienenunterstützung	1		
	Left rail support	Support rail de guidage gauche	Linker schienenunterstützung	1		
	Securing knob M8X 20	Bouton étoile à tige filetée M8X20	FeststellSchrauben M8X20	2		
	screw ISO7047 - M5x20	vis ISO7047 - M5x20	Schraube ISO7047 - M5x20	2		
	washer DIN6798 - M5	rondelle ISO6798 - M5	Scheibe ISO6798 - M5	2		
	washer DIN127 - M5	rondelle DIN127 - M5	Scheibe DIN127 - M5	2		
	Arrow indicator	Flèche indicateur	Pfeilanzeige	2		
	Indicator axes	Axe d'indicateur	Anzeigestift	2		
	graduated Sticker	Autocollant gradué	Staffel Sticker	2		
	Rail support left and right	Support de rail gauche et droite	Schienträger links und rechts	1		
	screw DIN 933 - M6x35	vis DIN 933 - M6x35	Schraube DIN 933 - M6x35	2		
	washer DIN 125 - M6	rondelle DIN 125 - M6	Scheibe DIN 125 - M6	6		
	nut ISO10511 - M6	ecrou ISO10511 - M6	Mutter ISO10511 - M6	2		

Feet / Pieds / Füße



POS.	DESCRIPTION	DESCRIPTION	BESCHREIBUNG	QTY	REF	TYPE
31	Securing knob	Bouton étoile de sécurité	Sicherheits-Stern-Knopf	1	510126264	S
	Securing knob M5	Bouton étoile M5	Feststellmutter M5	2		
	blocking plate	plaque de bloquage	Blockierplatte	1		
32	blocking arm kit	Kit Bras de Blocage	Sperrarm kit	1	510126265	S
	Right arm	Bras droit	Rechter Arm	1		
	Left arm	Bras gauche	Linker Arm	1		
	screw ISO2010 - M5x43	vis ISO2010 - M5x43	Schraube ISO2010 - M5x43	2		
	washer ISO7089 - M5	rondelle ISO7089 - M5	Scheibe ISO7089 - M5	2		
	nut ISO10511 - M5	ecrou ISO10511 - M5	Mutter ISO10511 - M5	2		
	Spring	Ressort	Feder	2		
	Securing knob M5	Bouton étoile M5	Feststellmutter M5	2		
	blocking plate	plaque de bloquage	Blockierplatte	1		
	Nylon nut	ecrou frein	Nylon Mutter	4		
33	Handle assy. (SET OF 2)	Poignée complète (jeu de 2)	Transportgriffe, kompl. (Satz von 2)	1	510094503	S
	screw DIN 933 – M8X40	vis DIN 933 – M8X45	Schraube DIN 933 – M8X40	2		
	nut DIN 985 – M8	ecrou DIN 985 – M8	Nuss DIN 985 – M8	1		
	Handle	Poignée	Transportgriffe	2		
	Handle support	Support poignée	Transportgriffe Unterstützung	2		
34	Transport wheel (SET OF 2)	Roue de transport complète (jeu de 2)	Transporträder, kompl. (Satz von 2)	1	310378958	S
	screw DIN 603 – M6X40	vis DIN 603 – M6X40	Schraube DIN 603 – M6X40	8		
	washer DIN 9021 – Ø6,4	rondelle DIN 9021 Ø6,4	Scheibe DIN 9021 – Ø6,4	4		
	nut DIN 315 – M6	ecrou DIN 315 – M6	Nuss DIN 315 – M6	1		
	Wheel	Roue	Räder	2		
	Wheel Support	support de roue	Radträger	2		
	wheel axes	Axe de roue	Radachse	2		
35	Leveling screws (set of 2)	vis de mise à niveau (jeu de 2)	BereitstellungSchraube (satz von 2)	1	510094500	S
	screw M12	vis M12	Schraube M12	2		
	nut DIN467 - M12	ecrou DIN467 - M12	Mutter DIN467 - M12	2		
	Gum	Patin gomme	Gummischuh	2		
36	Back legs kit	Kit pieds arrière	Hinterer Fuß kit	1	510126266	S
	Back legs	Pieds arrière	Hinterer Fuß	1		
	screw ISO2010 - M5x43	vis ISO2010 - M5x43	Schraube ISO2010 - M5x43	2		
	screw DIN 85 M5x48	vis DIN 85 M5 x 48	Schraube DIN 85 M5x48	2		
	nut DIN985 - M5	ecrou DIN985 - M5	Mutter DIN985 - M5	4		
	washer DIN EN ISO 7090 - M5	rondelle DIN EN ISO 7090 - M5	Scheibe DIN EN ISO 7090 - M5	4		
37	Front legs kit	Kit pieds avant	Vorderer Fuß kit	1	510126267	S
	Front legs	Pieds avant	Vorderer Fuß	1		
	screw ISO2010 - M5x43	vis ISO2010 - M5x43	Schraube ISO2010 - M5x43	2		
	screw DIN 85 M5x48	vis DIN 85 M5x48	Schraube DIN 85 M5x48	2		
	nut DIN985 - M5	ecrou DIN985 - M5	Mutter DIN985 - M5	4		
	washer DIN EN ISO 7090 - M5	rondelle DIN EN ISO 7090 - M5	Scheibe DIN EN ISO 7090 - M5	4		
38	Frame assy	Cadre complet	Rahmen komp	1	510101039	S
	Frame	Cadre	Rahmen	1		
	Back legs	Pieds arrière	Hinterer Fuß	1		
	Front legs	Pieds avant	Vorderer Fuß	1		
	screw ISO2010 - M5x48	vis ISO2010 - M5x48	Schraube ISO2010 - M5x48	4		
	washer ISO7089 - M5	rondelle ISO7089 - M5	Scheibe ISO7089 - M5	8		
	nut ISO10511 - M5	ecrou ISO10511 - M5	Mutter ISO10511 - M5	8		
	screw ISO2010 - M5x43	vis ISO2010 - M5x43	Schraube ISO2010 - M5x43	4		
	screw ISO4016 - M8x50	vis ISO4016 - M8x50	Schraube ISO4016 - M8x50	4		
	washer ISO7089 - M8	rondelle ISO7089 - M8	Scheibe ISO7089 - M8	8		
	nut ISO10511 - M8	ecrou ISO10511 - M8	Mutter ISO10511 - M8	4		
39	Toolkit	Kit outils	Werkzeug	1	510126269	S
	Wrench 18mm	Clé 18 mm	Schraubenzieher 18mm	1		
	Wrench 8mm	Clé 8mm	Schraubenzieher 8mm	1		
	screw driver	Tournevis cruciforme	Schraubenschlüssel	1		
	Hook for tools	Crochet pour outil	Haken für Werkzeug	1		
	nut ISO4032 - M5	ecrou ISO4032 - M5	Mutter ISO4032 - M5	2		

SAINT-GOBAIN ABRASIVES NV/SA
INDUSTRIELAAN 129
1070 ANDERLECHT : BRUSSEL
BELGIUM
TEL: +32 2 267 21 00
FAX: +32 2 267 84 24

SAINT-GOBAIN ABRASIVES, S.R.O.
VINOHRADSKÁ 184
130 52 PRAHA 3
CZECH REPUBLIC
TEL: +420 267 132 026
+420 267 132 029
FAX: +420 267 132 021-2

SAINT-GOBAIN ABRASIVES A/S
ROBERT JACOBSENS VEJ 62A
2300 KØBENHAVN S
DENMARK
TEL: +45 4675 5244

PO BOX 643706
FORTUNE TOWER OFFICE 2106
JLT BLOCK C
(NEXT TO METRO STATION)
JUMEIRA LAKE TOWER, DUBAI
UNITED ARAB EMIRATES
TEL: +971 4 431 5154
FAX: +971 4 431 5434

SAINT-GOBAIN ABRASIFS
RUE DE L'AMBASSADEUR - B.P.8
78 702 CONFLANS CEDEX
FRANCE
TEL: +33 (0)1 34 90 40 00
FAX: +33 (0)1 39 19 89 56

SAINT-GOBAIN ABRASIVES GMBH
BIRKENSTRASSE 45-49
D-50389 WESSELING
GERMANY
TEL: +49 (0) 2236 703-1
+49 (0) 2236 8996-0
+49 (0) 2236 8911-0
FAX: +49 (0) 2236 703-367
+49 (0) 2236 8996-10
+49 (0) 2236 8911-30

FÜR DEN FACHHANDEL ÖSTERREICH
TEL: +43 (00) 662 430 076

SAINT-GOBAIN ABRASIVES KFT.
1225 BUDAPEST
BÁNYALÉG U. 60/B.
HUNGARY
TEL: +36 1 371 22 50
FAX: +36 1 371 22 55

SAINT-GOBAIN ABRASIVI S.P.A
VIA PER CESANO BOSCONI 4
I-20094 CORSICO MILANO
ITALY
TEL: +39 02 44 851
FAX: +39 02 44 78 266

SAINT-GOBAIN ABRASIVES S.A.
190 RUE J.F. KENNEDY
L-4930 BASCHARAGE
GRAND DUCHE DE LUXEMBOURG
TEL: +352 50 401 1
FAX: +352 50 16 33
NO. VERT (FRANCE) 0800 906 903

SAINT-GOBAIN ABRASIFS, S.A.
2 ALLÉE DES FIGUIERS
AIN SEBAÂ - CASABLANCA
MOROCCO
TEL: +212 5 22 66 57 31
FAX: +212 5 22 35 09 65

SAINT-GOBAIN ABRASIVES BV
GROENLOSEWEG 28
7151 HW EIBERGEN
P.O. BOX 10
7150 AA EIBERGEN
THE NETHERLANDS
TEL: +31 545 466466
FAX: +31 545 474605

SAINT-GOBAIN ABRASIVES AS
POSTBOKS 11, ALNABRU,
0614 OSLO
BROBEKKVEIEN 84,
0582 OSLO
NORWAY
TEL: +47 63 87 06 00
FAX: +47 63 87 06 01

SAINT-GOBAIN HPM POLSKA SP. Z O.O.
UL. TORUŃSKA 239/241
62-600 KOŁO
POLAND
TEL: +48 63 26 17 100
FAX: +48 63 27 20 401

SAINT-GOBAIN ABRASIVOS, L. DA
ZONA INDUSTRIAL DA MAIA
I-SECTOR VIII, NO. 122
APARTADO 6050
4476 - 908 MAIA
PORTUGAL
TEL: +351 229 437 940
FAX: +351 229 437 949

SAINT-GOBAIN GLASS
BUSINESS UNIT ABRASIVI
PUNCT DE LUCRU: LOC.VETIS,JUD.
SATU MARE 447355
STR. CAREIULUI 11
PARC INDUSTRIAL RENOVATIO
ROMANIA
TEL: +40 261 839 709
FAX: +40 261 839 710

SG HPM RUS
58, F. ENGELS STR.
STROENIE 2
105082 MOSCOW
RUSSIA
TEL: +74 955 408 355
FAX: +74 959 373 224

SAINT-GOBAIN
ABRASIVES (PTY) LTD
2 MONTEER ROAD
ISANDO 1600
P.O. BOX 67
SOUTH AFRICA
TEL: +27 11 961 2000
FAX: +27 11 961 2184/5

SAINT-GOBAIN ABRASIVOS, S.A.
CTRA. DE GUIPÚZCOA, KM. 7,5
E-31195 BERRIOPLANO (NAVARRA)
SPAIN
TEL: +34 948 306 000
FAX: +34 948 306 042

SAINT-GOBAIN ABRASIVES AB
BOX 495
SE-191 24 SOLLENTUNA
SWEDEN
TEL: +46 8 580 881 00
FAX: +46 8 580 881 01

SAINT-GOBAIN ABRASIVES
MUEYYETZADE MAH.
GALIPDEDE CAD. NO:99, KAT:3
34425 BEYOGLU-ISTANBUL-TURKEY
TEL: 0090-212-245 85 21
FAX: 0090-212-245 85 27

SAINT-GOBAIN ABRASIVES LTD.
DOXEY RD
STAFFORD
ST16 1EA
UNITED KINGDOM
TEL: +44 1785 222 000
FAX: +44 1785 213 487