



ECO Slide rail SR-EF-2

Product information



■ SYSTEM TECHNOLOGY FOR THE DOOR

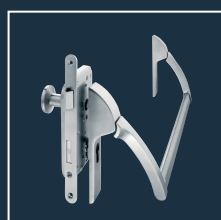
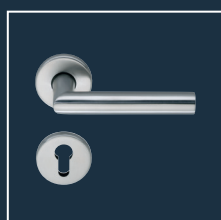

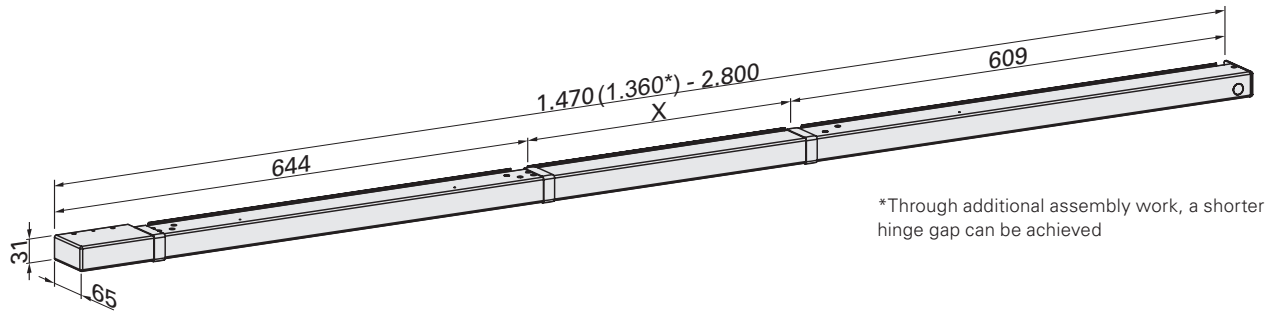
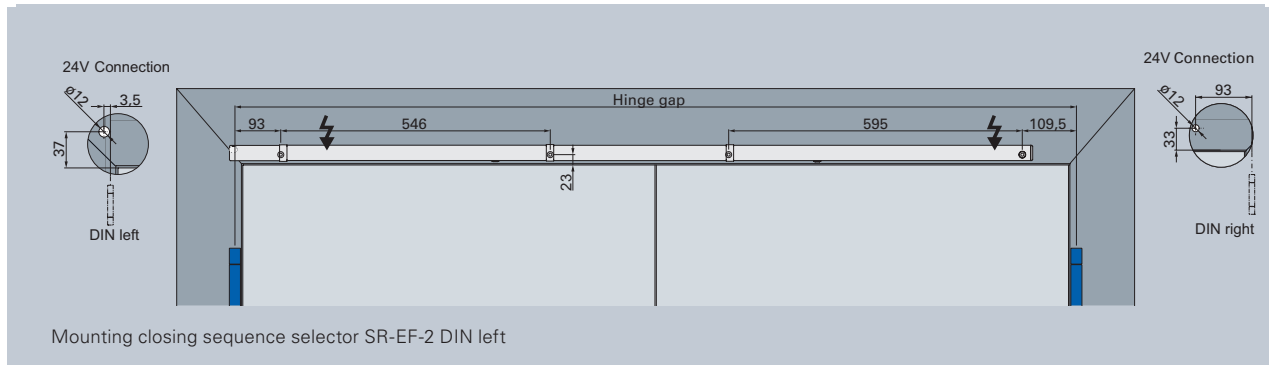

SR-EF-2

Closing sequence selector with electromagnetic hold-open in the active and passive leaf for ECO Newton TS-61, TS-41**

- **Hold open angle for passive leaf and active leaf**
 Active leaf: Approx. 70° to 145°, Passive leaf: 70° to 130°
- **Power consumption in hold-open position:**
 Supply voltage 24 V DC, max. 1 W
- **Minimum size passive leaf:**
 360 mm (for TS-41) bzw. 400 mm (for TS-61)
- **Scope of delivery:**
 Incl. corresponding cover profile and arm for slide rail B for TS-61**
- **Mounting:** Only hinge side.

- **Slide rail closing sequence selector:**
 The closing sequence selector ensures, that the door leaves are closing in the correct order. E.g.: the passive leaf first, active leaf last.
- **Electromagnetic hold-open:**
 In active and passive leaf. Active leaf is held open electromagnetically when opened. If passive leaf is opened additionally, it will be held open electromagnetically, too. At the same time the integrated closing sequence is activated which locks the active leaf. The magnet of the active leaf disconnects, both door leaves stay open.
- **Tested acc. to: EN 1155 and EN 1158.**

Closing sequence selector EF-2
 Hinge gap standard 1.470 (1.360*) – 2.800 mm

DIN left	Colour	Article number	DIN right	Colour	Article number
SR-EF-2 (Si)	Silver RAL 9006	350100000AK2511	SR-EF-2 (Si)	Silver RAL 9006	350100000AK2512
SR-EF-2 (W)	White RAL 9016	350100000EK2511	SR-EF-2 (W)	White RAL 9016	350100000EK2512
SR-EF-2 (Br)	Brown RAL 8014	350100000DK2511	SR-EF-2 (Br)	Brown RAL 8014	350100000DK2512
SR-EF-2 (S)	Black RAL 9005	350100000GK2511	SR-EF-2 (S)	Black RAL 9005	350100000GK2512
SR-EF-2 (ER M)	Stainless steel satin	350100000QK2511	SR-EF-2 (ER M)	Stainless steel satin	350100000QK2512
SR-EF-2 (ER P)	Stainless steel polished	On request	SR-EF-2 (ER P)	Stainless steel polished	On request

Accessories SR-EF-2 for double-leaf doors

DIN left / right	Colour	Article number
Standard profile SP-SR	Steel zinc plated	350300U10000000
Adaptor profile ADP-SR	Steel zinc plated	350300V10000000

When using in schools, caserns and stadiums as well as in areas with a high potential of vandalism, we recommend the use of eletromagnetic door retainers.

**When using the door closer TS-41, the correct arm has to be ordered.

ECO Mounting versions

Direct mounting

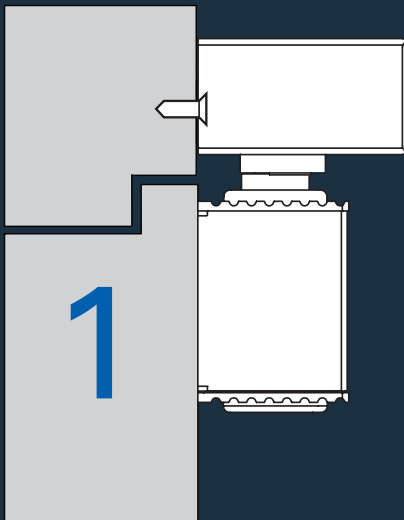

Direct mounting is the standard mounting at ECO. Slide rails is mounted directly onto the door frame. The ECO mounting holes need to be prepared. The respective mounting holes are shown on the next pages.

A paper drilling template is included in each box. Additionally, a metal drilling template (accessories, page 185) or respective mounting holes as PDF or DXF files are available.

Mounting with standard profile

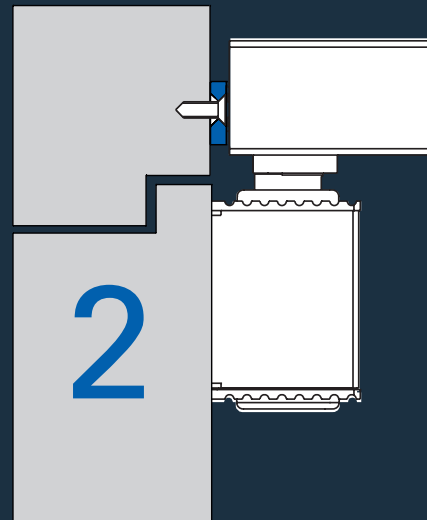

The mounting with the standard profile (SP) is used when the door frame is already equipped with the mounting drill holes 120/428,5 mm - e.g. for steel door frames or when exchanging / retrofitting.

The standard profile is mounted directly to the door frame and adapts the ECO drill holes to the prepared drill holes. It can be ordered separately as accessory.

Mounting with adaptor profile

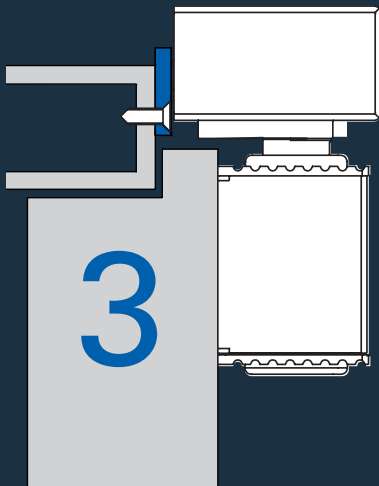

The adaptor profile (ADP) is being used when a stable mounting of the slide rail is not possible due to constructions (e.g. steel frame doors with double rebated notches). The adaptor profile is mounted directly to the door frame. The slide rail can be mounted onto the ADP and will be stable. It can be ordered separately as accessory.

The drilling dimensions for the adaptor profiles are included on the attached paper drilling template. Additionally, a metal drilling template (accessory page) or respective PDF or DXF files containing the dimensions can be available (www.eco-schulte.de)

Mounting with under-lintel angle

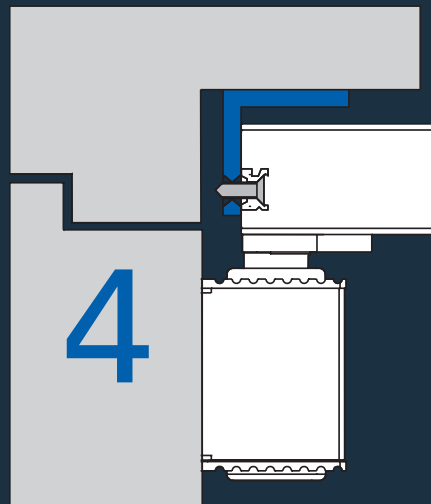

The under-lintel angle (SFW) is being used for installation on the hinge-opposite side if the slide rail needs to be mounted under the door frame (for doors with deep door lintels).

The under-lintel angle is screwed bottom-up to the door frame and the slide rails is fixed to the under-lintel angle.

The drilling dimensions for the SFW are mentioned in the mounting instruction or can be available as PDF or DXF file (www.eco-schulte.de). The under-lintel angle can be ordered separately as accessory.

ECO Schulte GmbH & Co. KG
Iserlohner Landstraße 89
D - 58706 Menden

Telefon: +49 2373/9276-0
Fax: +49 2373/9276-40

info@eco-schulte.de
www.eco-schulte.de

© ECO Schulte GmbH & Co. KG - Änderungen vorbehalten
© ECO Schulte GmbH & Co. KG - Subject to change