

PRODUCT DATA SHEET

TENSION ROD 340/440/540/620

PRODUCT DESCRIPTION

The tension rods 340 / 440 / 540 / 620 are moulded sheet steel parts especially for timber frame construction for transfer of tensile forces. They enable quick and easy base point anchoring of wooden elements in wood, steel or concrete substrates. The tension rods are particularly sturdy and can withstand high stresses.

ADVANTAGES

- Short root face (150 mm)
- Indirect fixing due to an intermediate layer (e.g. OSB)
- For installation in wood, steel and concrete
- Optimised screw pattern for very high tensile capacities



MATERIAL

- Galvanised S355 construction steel



Note

Tension rod 340/440 may only be used in combination with pressure plate tension rod 340/440 (item no.: 954110).

Tension rod 540/620 may only be used in combination with pressure plate tension rod 540/620 (item no.: 954230).

CERTIFICATION

- European Technical Assessment ETA -19/0020



PRODUCT DATA SHEET

TENSION ROD 340/440/540/620

TECHNICAL INFORMATION

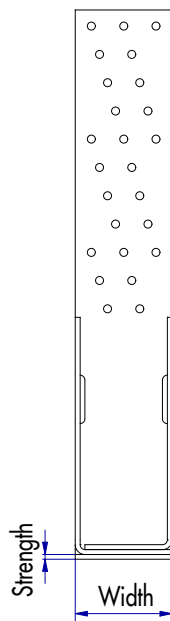

Side view

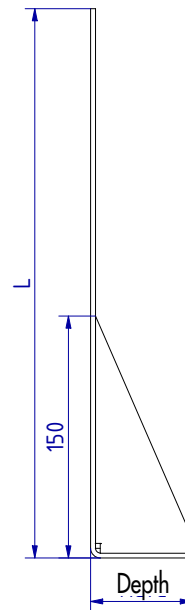

Front view

CHARACTERISTIC TENSION FORCE

Tension rod 340					
Quantity [n] 25	Wood fasteners				Steel
	Anchor nails	$F_{1,k}$ [kN]	Angle Bracket Screws (ABS)	$F_{1,k}$ [kN]	$F_{1,sk}$ [kN]
	4×40	47,5	5×40	53,5	57,1
	4×50	56,5	5×50	57,0	
4×60	61,3	5×60	60,8		

The load-bearing capacities were determined based on ETA-19/0020. Characteristic load-bearing capacities in kN were specified for timber strength class of C24 with a characteristic density of 350 kg/m³. The minimum distances between the connecting elements and the edges in line with EC5 must be observed. For the design values under wind loads, $\gamma_{m,timber} = 1.3$ and $k_{mod} = 0.9$ should be used for screws. $\gamma_{m,steel} = 1.25$ should be used for steel plates.

Note: The values for cracked concrete are still being provisioned. The calculated values were determined using the appropriate pressure plate.

PRODUCT DATA SHEET

TENSION ROD 340/440/540/620

Tension rod 440					
Quantity [n] 34	Wood fasteners				Steel
	Anchor nails	F _{1,k} [kN]	Angle Bracket Screws (ABS)	F _{1,k} [kN]	F _{1,Rk} [kN]
	4×40	64,6	5×40	72,8	79,4
	4×50	76,8	5×50	77,5	
4×60	83,3	5×60	82,6		

The load-bearing capacities were determined based on ETA-19/0020. Characteristic load-bearing capacities in kN were specified for timber strength class of C24 with a characteristic density of 350 kg/m³. The minimum distances between the connecting elements and the edges in line with EC5 must be observed. For the design values under wind loads, $\gamma_{m,timber} = 1.3$ and $k_{mod} = 0.9$ should be used for screws. $\gamma_{m,steel} = 1.25$ should be used for steel plates.

Note: The values for cracked concrete are still being provisioned. The calculated values were determined using the appropriate pressure plate.

Tension rod 540*					
Quantity [n] 43	Wood connections				Steel
	Anchor nails	F _{1,k} [kN]	Angle Bracket Screws (ABS)	F _{1,k} [kN]	F _{1,Rk} [kN]
	4×40	81,7	5×40	92,0	127,4
	4×50	97,2	5×50	98,0	
4×60	105,4	5×60	104,5		

The load-bearing capacities were determined based on ETA-19/0020. Characteristic load-bearing capacities in kN were specified for timber strength class of C24 with a characteristic density of 350 kg/m³. The minimum distances between the connecting elements and the edges in line with EC5 must be observed. For the design values under wind loads, $\gamma_{m,timber} = 1.3$ and $k_{mod} = 0.9$ should be used for screws. $\gamma_{m,steel} = 1.25$ should be used for steel plates.

* ETA-approval is pending.

Note: The values for cracked concrete are still being provisioned. The calculated values were determined using the appropriate pressure plate.

Tension rod 620*					
Quantity [n] 54	Wood fasteners				Steel
	Anchor nails	F _{1,k} [kN]	Angle Bracket Screws (ABS)	F _{1,k} [kN]	F _{1,Rk} [kN]
	4×40	102,6	5×40	115,6	159,2
	4×50	122,0	5×50	123,1	
4×60	132,3	5×60	131,2		

The load-bearing capacities were determined based on ETA-19/0020. Characteristic load-bearing capacities in kN were specified for timber strength class of C24 with a characteristic density of 350 kg/m³. The minimum distances between the connecting elements and the edges in line with EC5 must be observed. For the design values under wind loads, $\gamma_{m,timber} = 1.3$ and $k_{mod} = 0.9$ should be used for screws. $\gamma_{m,steel} = 1.25$ should be used for steel plates.

* ETA-approval is pending.

Note: The values for cracked concrete are still being provisioned. The calculated values were determined using the appropriate pressure plate.

PRODUCT DATA SHEET

TENSION ROD 340/440/540/620

INSTRUCTIONS FOR USE

The tension rods are placed on the planking in the floor area and fastened to the stem and, if necessary, to the sole plate with screws or anchor nails. In this regard, the connection can safely transfer tensile, suction and shearing forces into the tension rod via the screws and finally into the base plates via a dowel bolt.

PRODUCT TABLES

Tension rod 340 / 440 / 540 / 620				
Art. no.	Designation	Dimension [mm]	Matching pressure plate	PU
954099	Tension rod 340	340 x 63 x 3	Tension rod pressure plate 340/440 (954110)	1
954100	Tension rod 440	440 x 63 x 4	Tension rod pressure plate 340/440 (954110)	1
954231	Tension rod 540 ¹⁾	540 x 75 x 4	Tension rod pressure plate 540/620 (954230)	1
954232	Tension rod 620 ^{*1)}	620 x 75 x 5	Tension rod pressure plate 540/620 (954230)	1

* Exclusively compatible with pressure plate tension rod 540/620 (954230).

¹⁾ EIA-approval is pending.

Tension rod					
Tension rod		340	440	540	620
Steel Class		S355			
Height	H [mm]	340	440	540	620
Base	B [mm]	60	60	80	80
Depth	P [mm]	63	63	75	75
Thickness	t [mm]	3	4	4	5
Plate Hole Number	Ø 5	25	34	43	54
First hole position in vertical leg	c [mm]	155	185	215	207,5
Hole position in horizontal leg	m [mm]	33	33	37,5	37,5
Base Hole	[mm]	Ø 22	Ø 22	Ø 26	Ø 26
Concrete Anchor / timber bolt	[mm]	M20	M20	M24	M24
kr,II	-	1,4	1,4	1,5	1,5

PRODUCT DATA SHEET

TENSION ROD 340/440/540/620

FASTENER SPACING

Tension rod 340

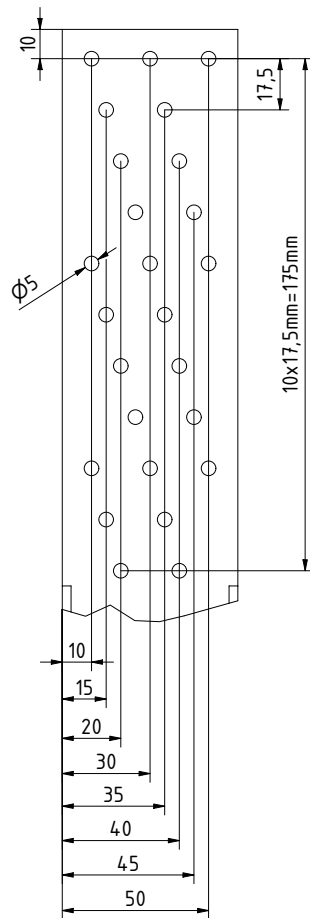

Front view

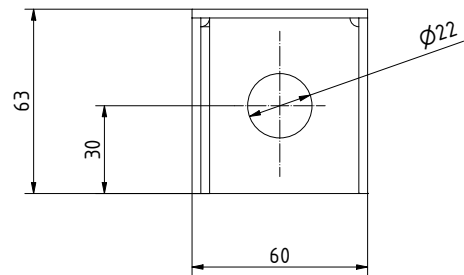

Top view

PRODUCT DATA SHEET

TENSION ROD 340/440/540/620

Tension rod 440

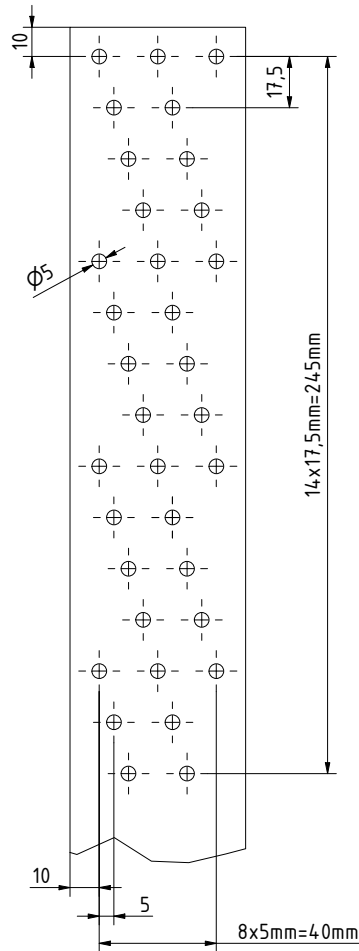

Front view

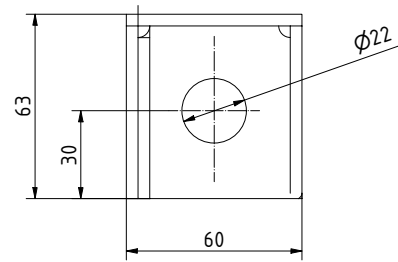

Top view

PRODUCT DATA SHEET

TENSION ROD 340/440/540/620

Tension rod 540

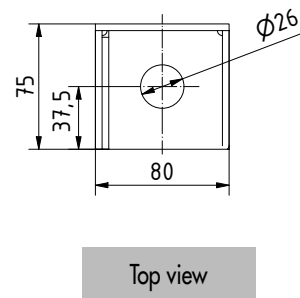
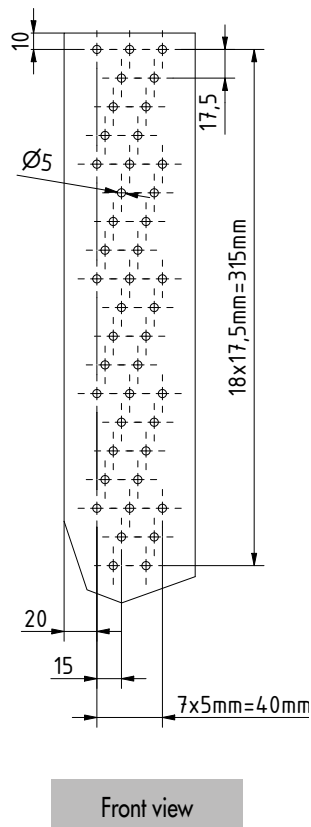

PRODUCT DATA SHEET

TENSION ROD 340/440/540/620

Tension rod 620

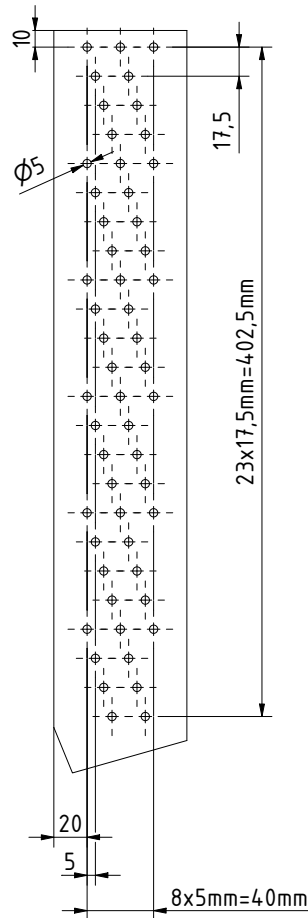

Front view

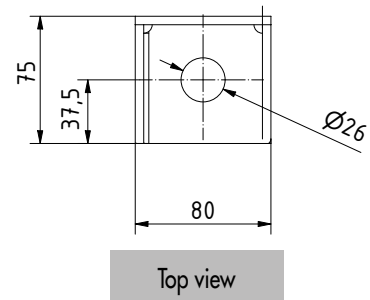

Top view

If you are not familiar with how this product is used, and particularly with the product's intended use, please contact our Application Technology department (Technik@eurotec.team).