

STROXX

PROUD PROFESSIONALS



ST-3 SMART LOCK

SCANDINAVIAN LOCK CASE

USER INSTRUCTION

Art. no. 102-676-677

- EN** Smart Lock
- DK** Smart Lock
- NL** Smart Lock
- DE** Smart Lock
- FR** Serrure connectée
- ES** Cerradura conectada









With hole
for cylinder
and turn

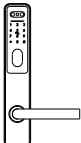
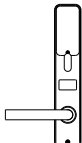

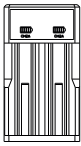
1. ACCESSORIES

EN

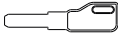
Check the packaging and accessories when you receive the lock.

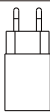
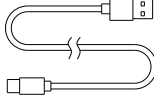
a  1 pcs. Front panel	b  1 pcs. Back panel	c  1 pcs. User manual	d  1 pcs. allen key	e  1 pcs. charger	f  2 pcs. batteries	
Door thickness Quantity	* G 	* H 	* I 	J  2 pcs. key	K  2 pcs. cards	
	40-50mm	8x8x70:1	4 pcs. M5X100	2 pcs. M5X16	L  1 pcs. power adapter	M  1 pcs. USB cable
	51-60mm	8x8x80:1				
	61-70mm	8x8x90:1				
	71-80mm	8x8x100:1				
	81-90mm	8x8x110:1				
91-100mm	8x8x120:1					

2. PRODUCT OVERVIEW

FRONT PANEL

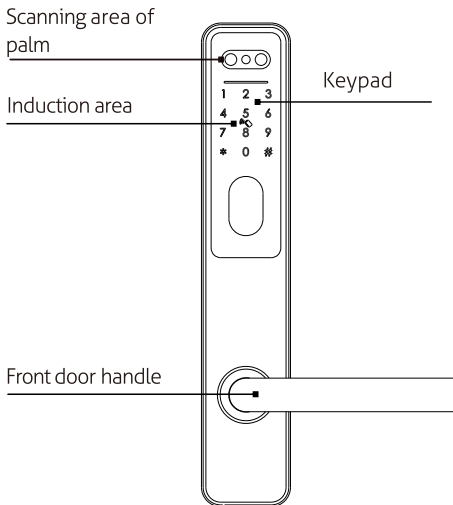

BACK PANEL

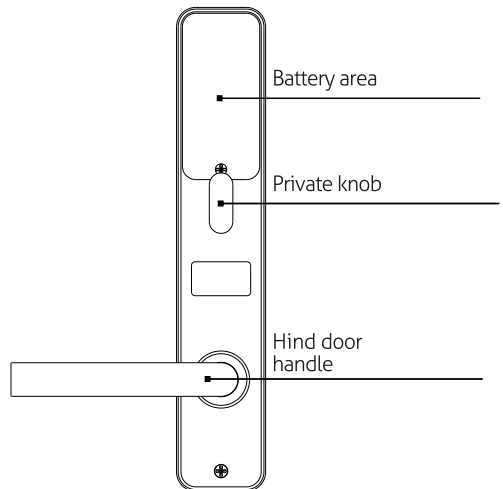

OPENING AND CLOSING

Enter the valid password, press the IC card or palm recognition to open the door

3. SYSTEM INTRODUCTION

STROXX

Material	Stainless steel, ABS, glass
Available colours	Silver brushed metal / matte black
Door thickness	40-100 mm
Communication	BLE5.0
Supported operating system	iOS 7.0 or later, Android 4.4 or later
Battery life	2000 times normal unlocking (3 months)
Power	DC 7.4 V: 2 x 18650 batteries
Static current	< 50 uA
Dynamic current	< 250 mA
Unlock	IC card, password, palm print, key, APP
Lock time	1-1.5 seconds
Working temperature	-20C°~50C° degrees
Working humidity	10-95 %
Factory code	Factory default main access code: 123456, after configuration it will be invalid
Virtual access code	Available
User capacity	Card: 1,000, password: 250, palm: 100, 1 administrator

4. RESET TO FACTORY SETTINGS



There is a reset button on the back of the rear panel. You can press this button for 3 seconds with the audio prompt, "Enter initialisation code", enter: 000#, with audio: "Successful". The lock is then in factory settings, the default master access code is: 123456

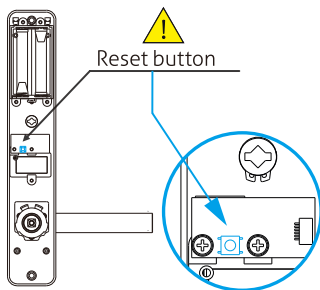

DEADLOCK FUNCTION

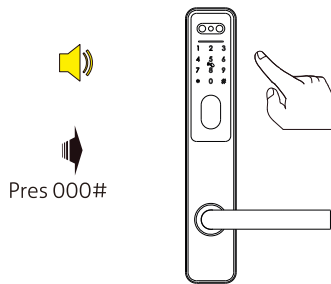

Factory setting:
Master access code:
123456

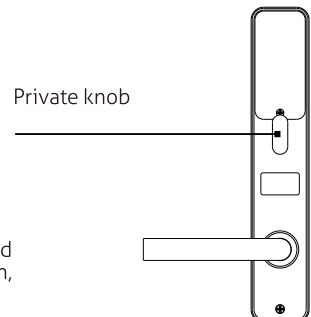

There is a private knob on the rear panel. You can turn this knob to the locked position. Please note that this will override the electronic unlocking function, so that unlocking can only be done from the outside using the key cylinder and then electronic unlocking. By turning the knob to the unlocked position, the lock will function normally again with electronic unlocking.

5. INFORMATION AND SAFETY WARNING

EN

5.1 INTRODUCTION

This user manual will guide you through the features and use of our ST-3 Smart Lock. It is important that you follow the instructions and take note of all the comments in this manual. Please read this manual before attempting to use this lock. If you have questions that are not answered in this manual, or require non-routine service, please call our customer service line or send us an FAQ.

5.2 SAFETY WARNINGS

When reading this manual, please pay attention to the following icons: Notes with the icon  Must be read, understood, and followed to avoid personal injury or damage to the lock.

GENERAL USE

- This lock may only be used as described in this manual.
- Check that all parts of the lock are present. If any parts are missing, please contact our service representative.
- In the factory setting, the lock is always open when you have installed it (without power). This means that the handle is free and the lock cannot be locked. You must turn on the lock with batteries or set up the administrator and pair the lock with the app, after which the lock will automatically be in private mode.
- The direction of the handle can be reversed. Please refer to Chapter 6 to change the direction if the door opening direction is not the same as your lock. If you have any problems, please contact our service technician.
- There is a protective film on the front touch panel. If there are scratches on the film, remove it if necessary.
- Use 2 x 18650 batteries. Do not mix old and new batteries.
- Never insert any objects into the lock other than the batteries described in this manual.
- Ensure that all surfaces are flat and level before beginning installation. Installation on doors or surfaces with any type of deformity, such as gaps or twists, may cause the lock to function poorly or not at all.
- Never apply cleaning agents directly to any part of this lock. Only use clean water or a mild cleaning agent on a soft, nonabrasive cloth when cleaning the lock.
- Potential shock hazard warning: Do not allow water or liquids to enter the electrical parts of the lock.
- The lock must be used with the XLOCK APP. The lock will work without the APP, but full functionality is only achieved when the APP is in use.

5.4 PAY SPECIAL ATTENTION TO

Remember to replace the battery when the battery alarm is activated.
Please read this manual carefully before installation and keep it for future reference.

Your local STROXX dealer handles warranties and complaints on behalf of Stroxx in Germany. You can read more about our warranty terms and conditions by visiting the following link: stroxx.eu/pages/warranty

6. PREPARATION FOR INSTALLATION

6.1 Line drawing

First assemble the mortise, then the cylinder, strike plate and strike box.

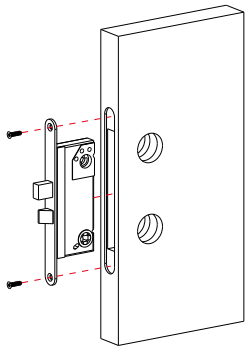

Step 1. Assemble the mortise

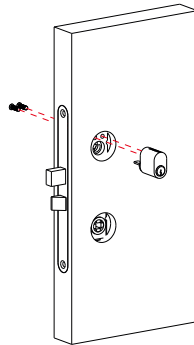

Step 2. Assemble the cylinder

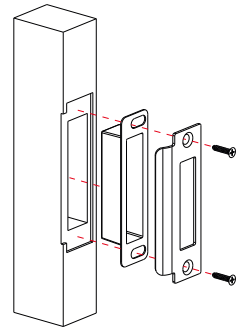

Step 3. Drill hole for strike plate/box

6.2 Determining the direction of the handle

The door handle is determined based on the secure side. The term "secure" means the side from which you initially unlock and enter the door from the outside, or the hinge side for left/right opening.

⚠ When standing outside the door, there is left/right opening and push/pull to open, as shown in the diagram below:

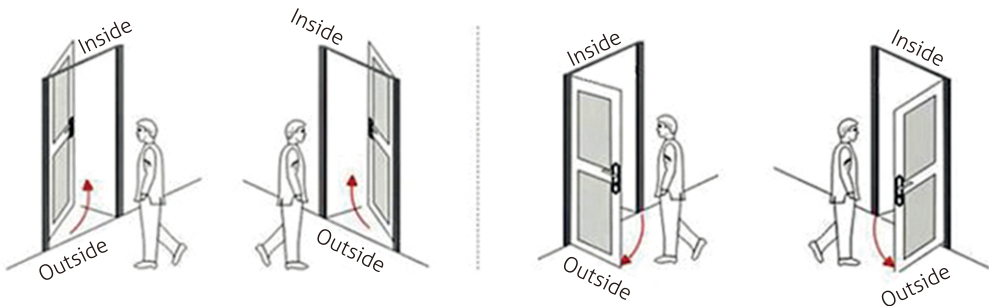

A

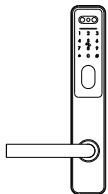

Left pressure

B

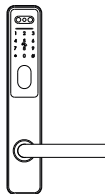

Right pressure

C

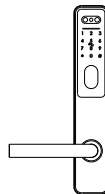

Left pressure

D

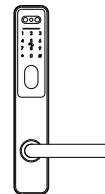

Right pressure

6.3 CHANGE HANDLE DIRECTION

EN

Adjust the front handle direction (from right to left)

6.3.1 Use the Allen key to remove the screw and handle.

6.3.2 Turn the handle 180 degrees counterclockwise.

6.3.3 Once the handle has been turned all the way round, refit the screw and handle and tighten securely.

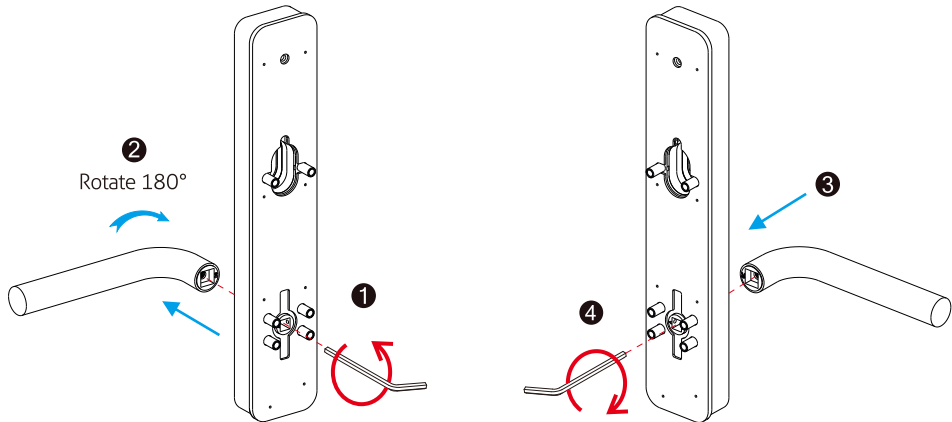

Adjust the direction of the rear handle

6.3.4 Use the Allen key to remove the screw and handle.

6.3.5 Turn the handle 180 degrees clockwise.

6.3.6 Once the handle has been turned all the way round, refit the screw and handle and tighten securely.

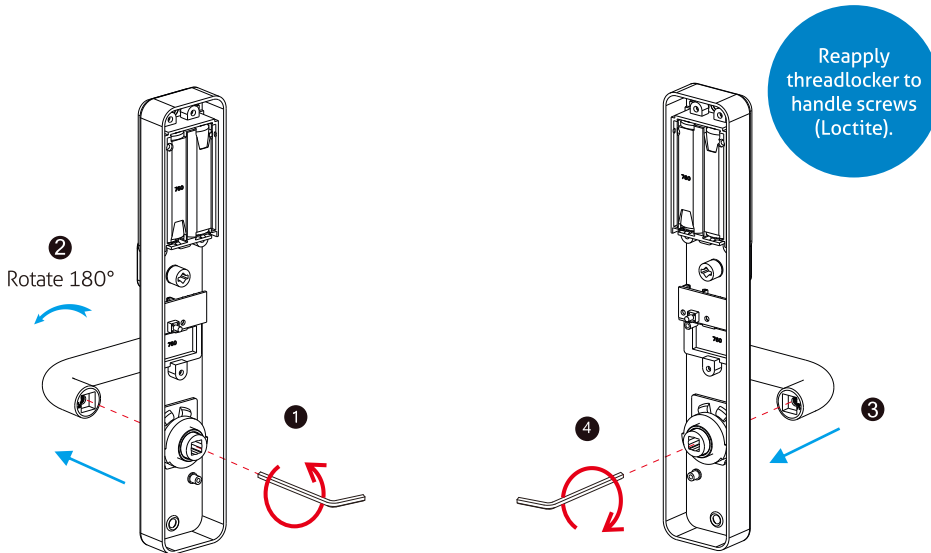

6.4 CHANGE THE DIRECTION OF THE TRIANGULAR TIP

STROXX

Ensure that the direction of the triangle tip matches the handle.

6.4.1 If the handle points to the left, turn the triangle to the left.

6.4.2 If the handle points to the right, turn the triangle tip to the right.

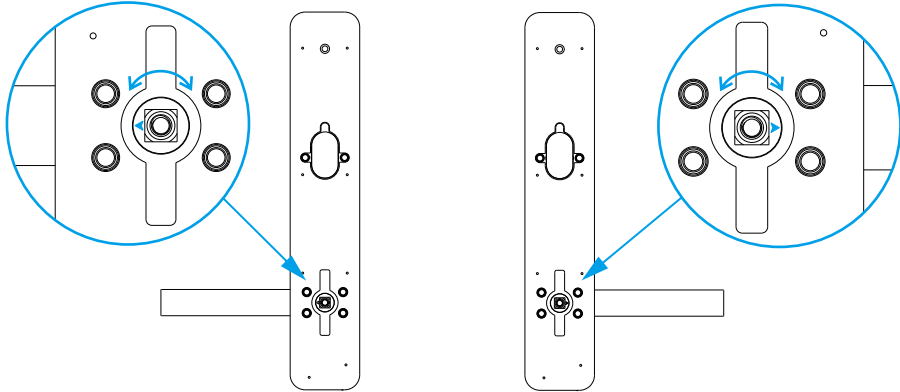

6.5 INSTALLATION-ASSEMBLY

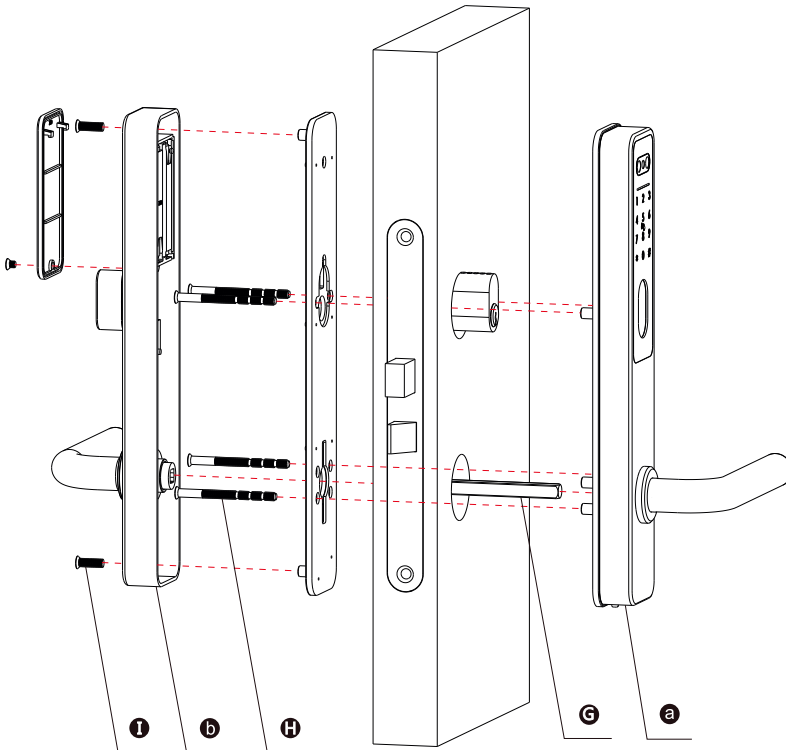

7. STEPS FOR INSTALLING THE LOCK

EN

7.1 Assemble the lock bracket and cylinder

Assemble the lock bracket and cylinder in the slot.

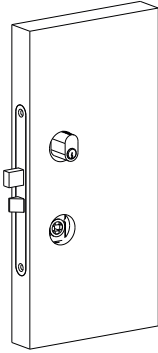

7.3 Connect the cable

7.3.1 First connect the wires.

7.3.2 Fit the spindles (G) into the hole.

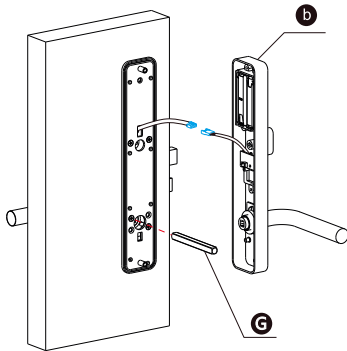

7.5 Assemble the battery box

Insert 2 x 18650 batteries and secure the battery box lid.

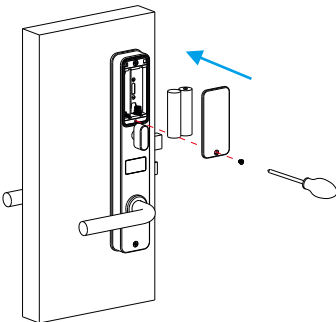

7.2 Fit the front panel

7.2.1 Attach the front panel (a) to the door and feed the cable through the hole.

7.2.2 Shorten the screw to a suitable length in relation to the thickness of the door.

7.2.3 Tighten the screw (H) to the rear cover with the front panel's solenoid valve.

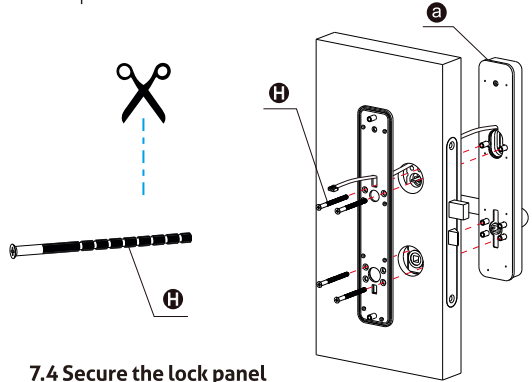

7.4 Secure the lock panel

First remove the battery compartment cover, then secure the rear panel (b) with the rear cover using the two screws (p).

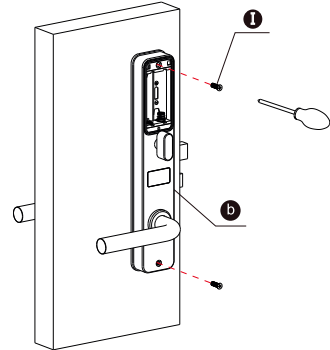

7.6 Adjust the locking panel

Once installation is complete, adjust the position of the lock panel or the screws if it is too tight. Insert the key and turn it, then press the handle to open.

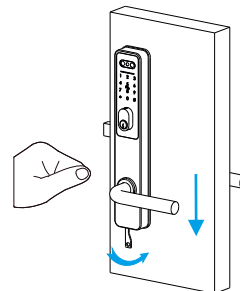

8. ADD YOUR SMART LOCK TO THE XLOCK APP

STROXX

Note: It is necessary to register the new administrator before you start using this lock.

You can follow the steps below:

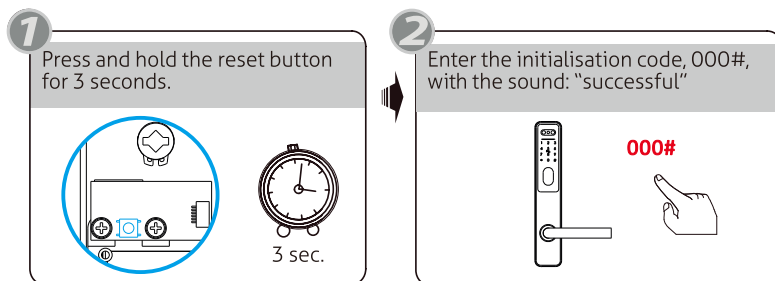

Download XLOCK from the Apple Store or Google Play. You can also scan the QR code below to download the app directly.



Scan the QR code
to get instructions for
the APP and more



Bluetooth



Pin Code



Manual key



Palmprint









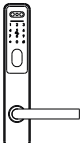
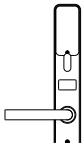

Card

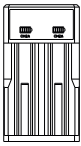
1. TILBEHØR

DK

Kontroller emballagen og tilbehøret, når du har modtaget låsen.

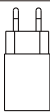
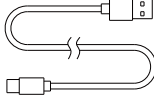
a  1 stk. Frontpanel	b  1 stk. Bagpanel	c  1 stk. Brugervejledning	d  1 stk. unbrakonøgle	e  1 stk. oplader	f  2 stk. batterier
Dørtykkelse Antal	* G 	* H 	* I 	J  2 stk. nøgle	K  2 stk. kort
	40-50mm	8x8x70:1	4 stk. M5X100	L  1 stk. strømadapter	M  1 stk. USB-kabel
	51-60mm	8x8x80:1			
	61-70mm	8x8x90:1			
	71-80mm	8x8x100:1			
	81-90mm	8x8x110:1			
91-100mm	8x8x120:1	2 stk. M5X16			

2. PRODUKTOVERSIGT

FORPANEL

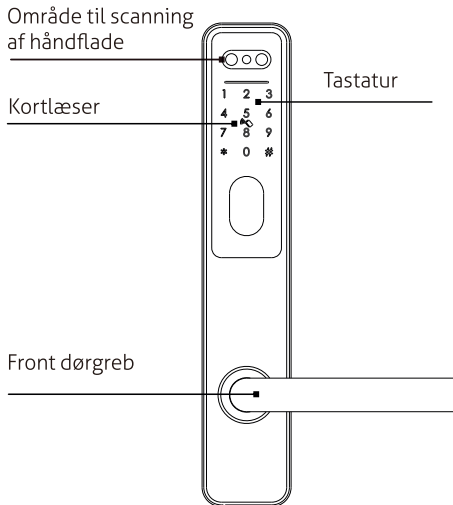

BAGPANEL

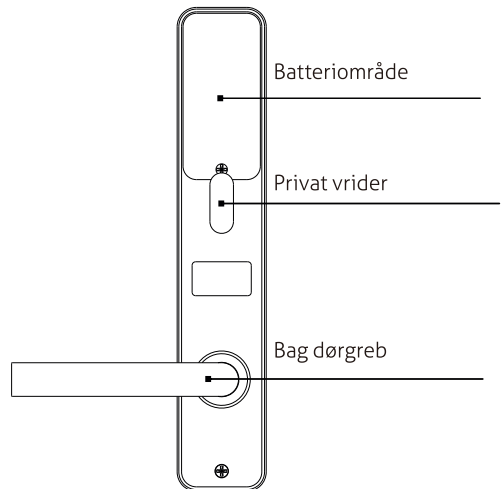

ÅBNING OG LUKNING

Indtast den gyldige adgangskode, vis kortet eller håndflade for at åbne døren

3. SYSTEM INTRODUKTION

STROXX

Materiale	Rustfrit stål, ABS, glas
Tilgængelige farver	Sølvfarvet børstet rustfrit / mat sort
Dørtykkelse	40-100 mm
Kommunikation	BLE5.0
Understøttet operativsystem	iOS 7.0 eller nyere, Android 4.4 eller nyere
Batterilevetid	2000 gange normal oplåsning (3 måneder)
Strømforsyning	DC 7.4 V: 2 stk. 18650-batterier
Statisk strøm	< 50 uA
Dynamisk strøm	< 250 mA
Lås op	Kort, adgangskode, håndfladeaftryk, nøgle, APP
Låse-tid	1-1.5 sekunder
Arbejdstemperatur	-20C°~50C° grader
Arbejdsfugtighed	10-95 %
Fabrikskode	Fabriksindstillet kode: 123456, efter konfiguration vil den være ugyldig
Virtuel adgangskode	Tilgængelig
Brugerkapacitet	Kort: 1.000, adgangskode: 250, håndflade: 100, 1 administrator

4. NULSTIL TIL FABRIKSINDSTILLINGER

⚠ VÆR OPMÆRKSOM

Der er en nulstillingsknap på bagsiden af bagpanelet. Du kan trykke på denne knap i 3 sekunder ved lydtp, "Indtast initialiseringskode", indtast: 000#, med lyd: "Succesfuld". Derefter er låsen i fabriksindstilling, standard-masteradgangskoden er: 123456

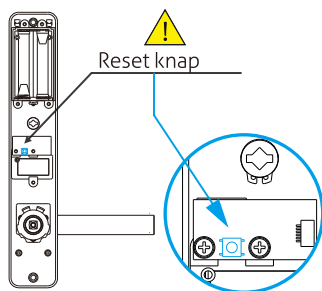

DØDLÅS-FUNKTION

⚠ VÆR OPMÆRKSOM

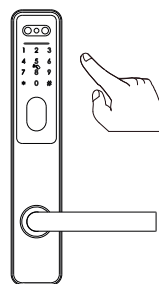

Fabriksindstilling:
Master adgangskode:
123456

Privat vrider

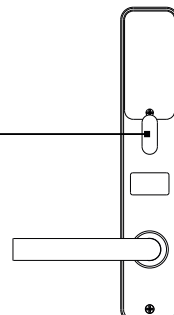

Der er en privat vrider på bagpanelet. Du kan dreje denne vrider til låst position, bemærk dette vil overstyre den elektronisk oplukning, så oplåsning kun kan ske fra udv. side med nøglecylinder og herefter elektronisk oplåsning, ved at vride vrider til oplåst position vil låsen igen fungerer normalt med elektronisk oplåsning

5. INFORMATION OG SIKKERHEDSADVARSEL

DK

5.1 INTRODUKTION

Denne brugervejledning vil guide dig gennem funktionerne og brugen af vores ST-3 Smart lock. Det er vigtigt, at du følger instruktionerne og tager alle bemærkninger i denne vejledning til efterretning.

Læs denne vejledning, inden du forsøger at bruge denne lås. Hvis du har spørgsmål, der ikke besvares i denne vejledning, eller har brug for ikke-rutinemæssig service, bedes du ringe til vores kundeservicetelefon eller sende os en FAQ.

5.2 SIKKERHEDSADVARSLER

Når du læser denne vejledning, skal du være opmærksom på følgende ikoner: Bemærkninger med ikonet ⚠ Skal læses, forstås og overholdes for at undgå personskade eller beskadigelse af låsen.

GENEREL BRUG ⚠

- Denne lås må kun bruges som beskrevet i denne manual.
- Kontroller, at alle dele af låsen er til stede. Hvis der mangler dele, bedes du kontakte vores servicemedarbejder.
- I fabriksindstillingen er låsen altid åben, når du har installeret den (uden strøm). Det betyder, at grebet er frit, og låsen ikke kan låses. Du skal tænde låsen med batterier og indstille administrator og parre låsen med appen, hvorefter låsen automatisk vil være i privat tilstand.
- Grebets retning kan vendes. Følg venligst kapitel 6 for at ændre retningen, hvis dørens åbningsretning ikke er den samme som din lås. Hvis du har problemer, bedes du kontakte vores servicetekniker.
- Der er en beskyttelsesfilm på det forreste berøringspanel. Denne skal fjernes efter montering, ellers vil låsen ikke fungerer optimalt.
- Brug 2 stk. 18650-batterier. Bland ikke gamle og nye batterier.
- Indsæt aldrig andre genstande i låsen end de batterier, der er beskrevet i denne vejledning.
- Kontroller, at alle overflader er flade og vandrette, inden du påbegynder installationen. Installation på døre eller overflader med nogen form for deformitet, såsom mellemrum eller vridninger, kan medføre, at låsen fungerer dårligt eller slet ikke fungerer.
- Påfør aldrig rengøringsmidler direkte på nogen del af denne lås. Brug kun rent vand eller et mildt rengøringsmiddel på en blød, ikke-slibende klud, når du rengør låsen. Låsen kan vedligeholdes med syrefri olie for at modvirke evt. flyverust, gælder kun rustfrie dele.
- Advarsel om potentiel stødfare: Lad ikke vand eller væsker trænge ind i låsens elektriske dele.
- Låsen skal bruges sammen med XLOCK APP. Låsen fungerer uden APP'en, men skal altid programmeres via app først, med koder, kort eller håndflader, og disse kan kun ændres med app.

5.4 VÆR SÆRLIG OPMÆRKSOM PÅ

Husk at udskifte batteriet, når batterialarmen aktiveres.

Læs venligst denne vejledning omhyggeligt før installation og gem den til senere reference.

Din lokale STROXX-forhandler håndterer garanti og reklamationer på vegne af StroxX i Tyskland. Du kan læse mere om vores garantibetingelser ved at besøge følgende link: stroxx.eu/pages/garanti

6. FORBEREDELSE TIL INSTALLATION

STROXX

6.1 Linjetegning

Saml først låsekassen, derefter cylinderen, medbringer pladen og medbringer stang.

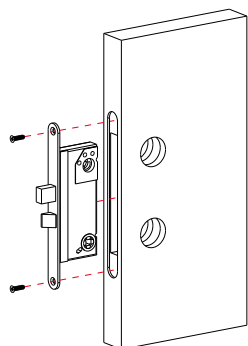

Trin 1. isæt låsekassen

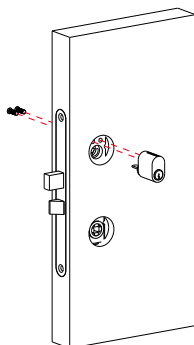

Trin 2. monter medbringer og cylinderen

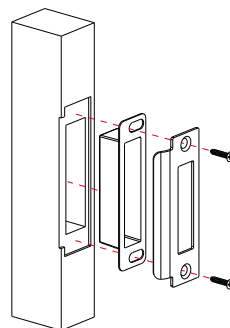

Trin 3. monter slutblik i dørkarm

6.2 Bestemmelse af grebets retning

Grebet bestemmes ud fra den sikre side. Udtrykket "sikker" betyder den side, hvorfra du oprindeligt låser op og går ind ad døren udefra, eller hængselsiden for venstre/højre åbning.

⚠ Når du står uden for døren, er der venstre/højre åbning og tryk/træk for at åbne, som vist i nedenstående diagram:

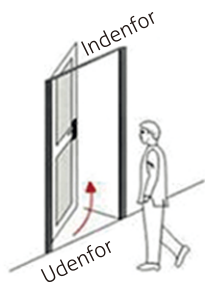

A

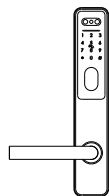

Venstre tryk

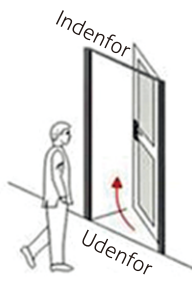

B

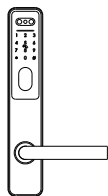

Højre tryk



C

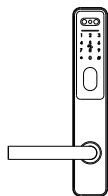

Venstre tryk

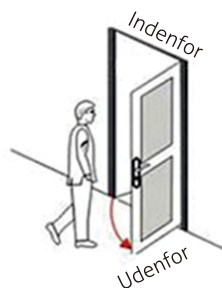

D

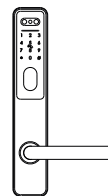

Højre tryk

6.3 SKIFT GREBSRETNING

DK

Juster den forreste grebsretning (fra højre mod venstre)

6.3.1 Brug unbrakonøglen til at fjerne skruen og grebet.

6.3.2 Drej grebet 180 grader mod uret.

6.3.3 Når grebet er drejet helt rundt, skal du montere skruen og grebet igen og stramme det godt fast.

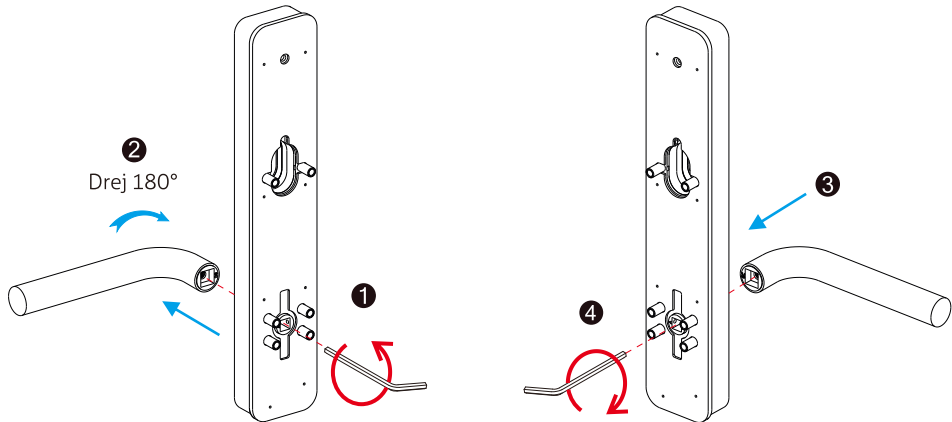

Juster baggrebets retning

6.3.4 Brug unbrakonøglen til at fjerne skruen og grebet.

6.3.5 Drej grebet 180 grader med uret.

6.3.6 Når grebet er drejet helt rundt, skal du montere skruen og grebet igen og stramme det godt fast.

6.3.7 Det er vigtigt at grebet spændes godt og skruen er påført skruesikring (Loctite)

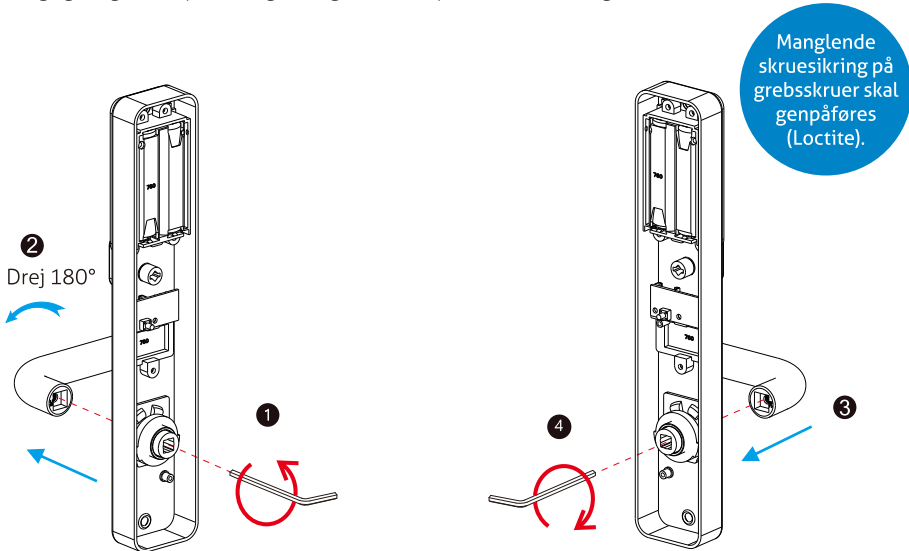

6.4 SKIFT RETNING PÅ TREKANTSPIDSEN

STROXX

Sørg for, at retningen af pilen stemmer overens med grebets.

6.4.1 Hvis grebet peger mod venstre, drej pilen mod venstre.

6.4.2 Hvis grebet peger mod højre, drej pilen mod højre.

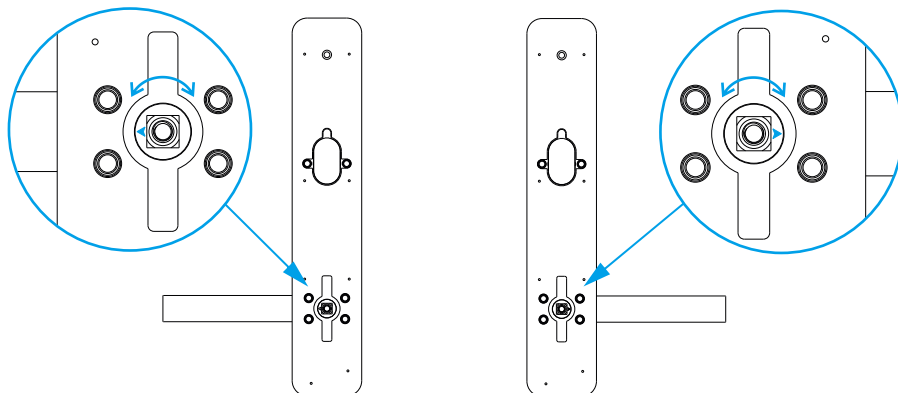

6.5 INSTALLATION-MONTERING

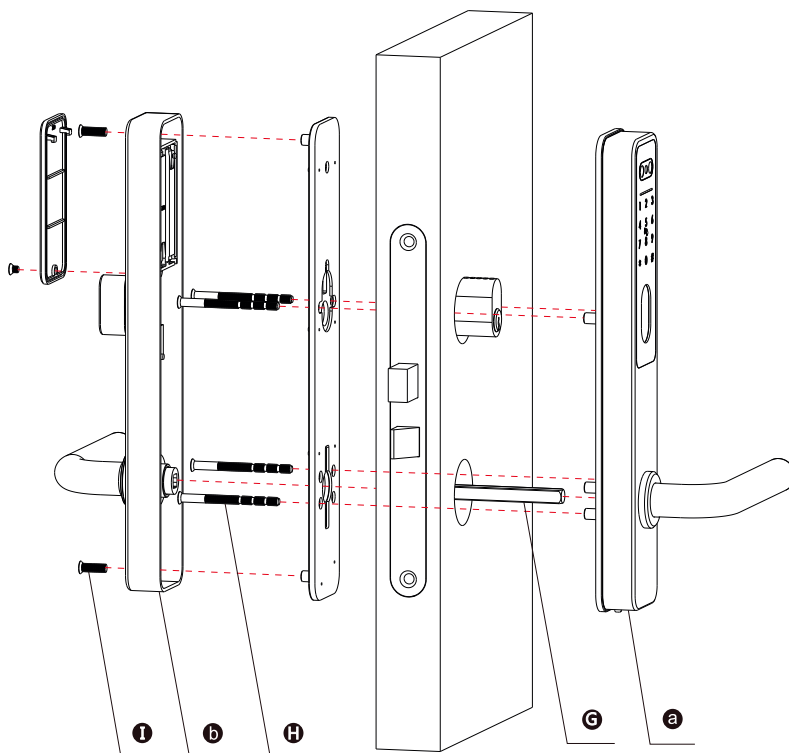

7. TRIN TIL MONTERING AF LÅS

DK

7.1 Monteret låsekasse og cylinder

Låsekassen med cylinder monteret i døren.

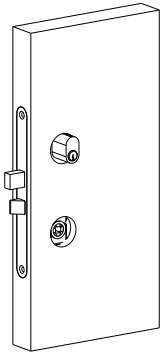

7.3 Tilslut kablet

7.3.1 Tilslut først ledningerne.

7.3.2 Monter grebspinden (G) i hullet.

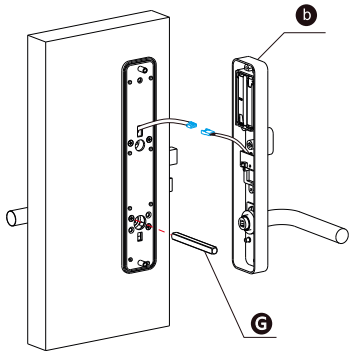

7.5 Saml batterikassen

Sæt 2 stk. 18650-batterier i, og fastgør batterikassens låg.

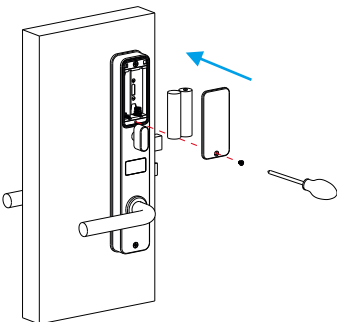

7.2 Monter frontpanelet

7.2.1 Fastgør frontpanelet (a) på døren, og før kablet gennem hullet over låsekassen.

7.2.2 Afkort skrueerne til en passende længde i forhold til dørens tykkelse.

7.2.3 Spænd skruen (H) til bagdækslet med frontpanelets skrueterminaler.

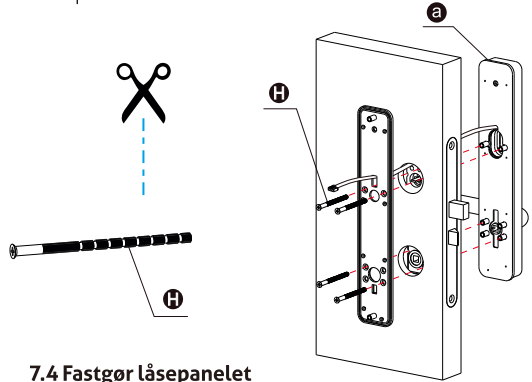

7.4 Fastgør låsepanelet

Fjern først batterikassens dæksel, og fastgør derefter bagpanelet (b) med bagdækslet med de to skrue (p).

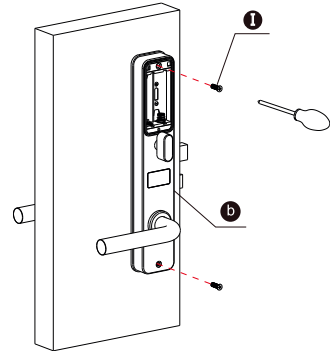

7.6 Juster låsepanelet

Når installationen er afsluttet, skal du justere låsepanelets position eller skrueerne, hvis det sidder for stramt. Indsæt nøglen og drej den, og tryk derefter på grebet for at åbne.

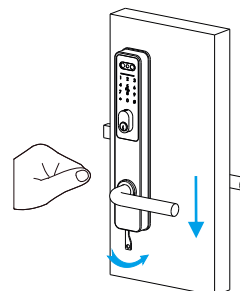

8. TILFØJ DIN SMART LOCK TIL XLOCK APP

STROXX

Bemærk: Det er nødvendigt at registrere den nye administrator, før du begynder at bruge denne lås.

Du kan følge nedenstående trin:

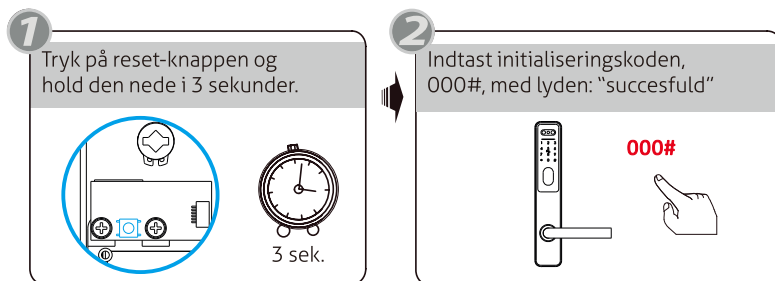

Download XLOCK fra Apple Store eller Google Play. Du kan også scanne QR-koden nedenfor for at downloade appen direkte.



Scan QR-koden for
at få vejledning til APP
med mere



Bluetooth



Pincode



Nøgle



Håndflade-
aftryk











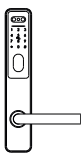
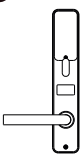

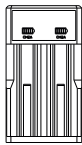
Kort

1. ACCESSOIRES

NL

Controleer de verpakking en accessoires wanneer u het slot ontvangt.

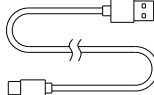
a  1 stuk Voorpaneel	b  1 stuk Achterpaneel	c  1 stuk Gebruikershandleiding	d  1 stuk inbusleutel el	e  1 stuk oplader	f  2 stuks batterijen	
Deurdikte Aantal	* G 	* H 	* I 	J  2 stuks sleutel	K  2 stuks kaarten	
	40-50mm	8x8x70:1	4 stuks M5X100	2 stuks M5X16	L  1 stuks voedingsadapter	M  1 stuks USB-kabel
	51-60mm	8x8x80:1				
	61-70mm	8x8x90:1				
	71-80mm	8x8x100:1				
	81-90mm	8x8x110:1				
91-100mm	8x8x120:1					

2. PRODUCTOVERZICHT

VOORPANEEL

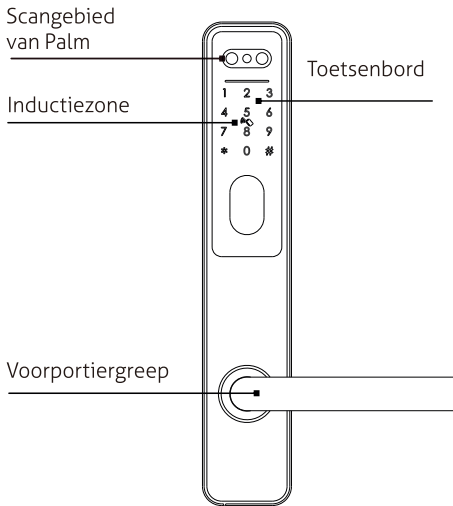

ACHTERPANEEL

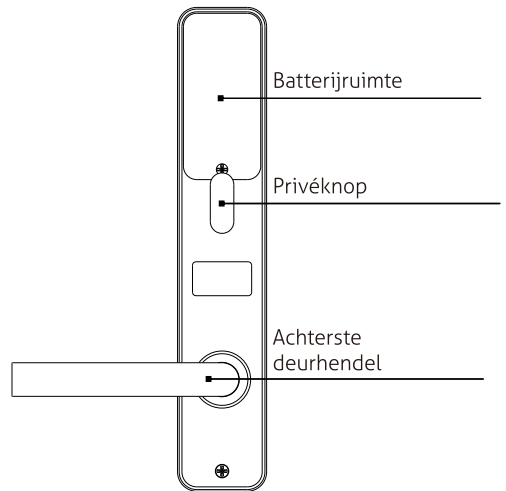

OPENEN EN SLUITEN

Voer het geldige wachtwoord in, druk op de IC-kaart of gebruik de handpalmherkenning om de deur te openen

3. SYSTEEMINTRODUCTIE

STROXX

Materiaal	Roestvrij staal, ABS, glas
Beschikbare kleuren	Zilver geborsteld metaal / matzwart
Deurdikte	40-100 mm
Communicatie	BLE5.0
Ondersteunde besturingssystemen	iOS 7.0 of hoger, Android 4.4 of hoger
Levensduur batterij	2000 keer normaal ontgrendelen (3 maanden)
Voeding	DC 7.4 V: 2 x 18650-batterijen
Statische stroom	< 50 uA
Dynamische stroom	< 250 mA
Ontgrendelen	IC-kaart, wachtwoord, handpalmafdruk, sleutel, app
Vergrendelingstijd	1-1,5 seconden
Werktemperatuur	-20C°-50C° graden
Bedrijfsvochtigheid	10-95 %
Fabriekscode	Standaard toegangscode van de fabriek: 123456, na configuratie is deze ongeldig
Virtuele toegangscode	Beschikbaar
Gebruikerscapaciteit	Kaart: 1.000, wachtwoord: 250, handpalm: 100, 1 beheerder

4. RESET NAAR FABRIEKINSTELLINGEN

 **LET OP**

Er zit een resetknop op de achterkant van het achterpaneel. Je kunt deze knop 3 seconden ingedrukt houden terwijl je de audioinstructie 'Voer initialisatiecode in' hoort, en dan 000# invoeren, waarna je de audio-instructie 'Geslaagd' hoort. Het slot staat dan op de fabrieksinstellingen en de standaard mastertoegangscode is: 123456

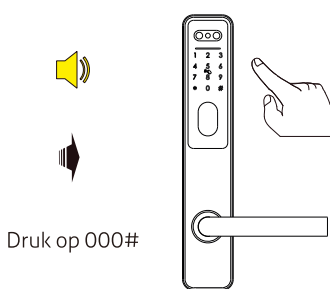
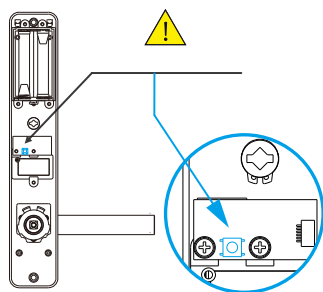

 Fabrieksinstelling:
Hoofdtoegangscode:
123456

DEADLOCK-FUNCTIE

 **LET OP**

Er zit een privé-draaiknop op het achterpaneel. Je kunt deze draaiknop naar de vergrendelde stand draaien, maar let op: dit overschrijft de elektronische ontgrendeling, zodat ontgrendeling alleen mogelijk is vanaf de buitenkant met een sleutelcilinder en vervolgens elektronische ontgrendeling. Door de draaiknop naar de ontgrendelde stand te draaien, werkt het slot weer normaal met elektronische ontgrendeling.

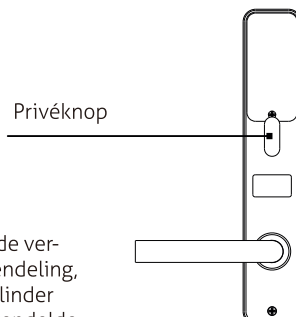

5. INFORMATIE EN VEILIGHEIDSWAARSCHUWING

NL

5.1 INLEIDING

Deze gebruikershandleiding leidt u door de functies en het gebruik van ons ST-3 Smart Lock. Het is belangrijk dat u de instructies volgt en alle opmerkingen in deze handleiding in acht neemt. Lees deze handleiding voordat u dit slot gaat gebruiken. Als u vragen heeft die niet in deze handleiding worden beantwoord, of als u niet-routinematige service nodig heeft, neem dan contact op met onze klantenservice of stuur ons een FAQ.

5.2 VEILIGHEIDSWAARSCHUWINGEN

Let bij het lezen van deze handleiding op de volgende pictogrammen: Opmerkingen met het pictogram  Moeten worden gelezen, begrepen en opgevolgd om persoonlijk letsel of schade aan het slot te voorkomen.

ALGEMEEN GEBRUIK

- Dit slot mag alleen worden gebruikt zoals beschreven in deze handleiding.
- Controleer of alle onderdelen van het slot aanwezig zijn. Neem contact op met onze klantenservice als er onderdelen ontbreken.
- In de fabrieksinstelling is het slot altijd open wanneer u het hebt geïnstalleerd (zonder stroom). Dit betekent dat de hendel vrij is en het slot niet kan worden vergrendeld. U moet het slot inschakelen met batterijen of de beheerder instellen en het slot koppelen aan de app, waarna het slot automatisch in de privémodus staat.
- De richting van de handgreep kan worden omgekeerd. Raadpleeg hoofdstuk 6 om de richting te wijzigen als de openingsrichting van de deur niet overeenkomt met die van uw slot. Neem bij problemen contact op met onze servicetechnicus.
- Er zit een beschermfolie op het touchpanel aan de voorkant. Als er krassen op de folie zitten, verwijder deze dan indien nodig.
- Gebruik 2 x 18650-batterijen. Gebruik geen oude en nieuwe batterijen door elkaar.
- Steek nooit andere voorwerpen in het slot dan de batterijen die in deze handleiding worden beschreven.
- Zorg ervoor dat alle oppervlakken vlak en waterpas zijn voordat u met de installatie begint. Installatie op deuren of oppervlakken met enige vorm van vervorming, zoals spleten of krommingen, kan ervoor zorgen dat het slot slecht of helemaal niet functioneert.
- Breng nooit schoonmaakmiddelen rechtstreeks op enig onderdeel van dit slot aan. Gebruik alleen schoon water of een mild schoonmaakmiddel op een zachte, niet-schurende doek om het slot schoon te maken.
- Waarschuwing voor mogelijk gevaar door elektrische schokken: Zorg ervoor dat er geen water of vloeistoffen in de elektrische onderdelen van het slot terechtkomen.
- Het slot moet worden gebruikt in combinatie met de XLOCK-app. Het slot werkt ook zonder de app, maar de volledige functionaliteit wordt alleen bereikt wanneer de app wordt gebruikt.

5.4 LET VOORAL OP

Vergeet niet de batterij te vervangen wanneer het batterijalarm wordt geactiveerd. Lees deze handleiding zorgvuldig door vóór de installatie en bewaar deze voor toekomstig gebruik.

Uw plaatselijke STROXX dealer behandelt de garantie en claims namens Stroxx in Duitsland. U kunt meer te weten komen over onze garantievoorwaarden via de volgende link: stroxx.eu/pages/garantie-nl

6. VOORBEREIDING VAN DE INSTALLATIE

STROXX

6.1 Lijntekening

Monteer eerst de insteekslot, daarna de cilinder, de sluitplaat en de sluitkast.

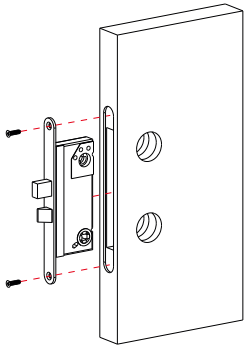

Stap 1. Monteer de pen

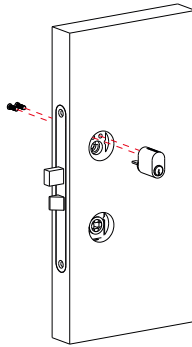

Stap 2. Monteer de cilinder

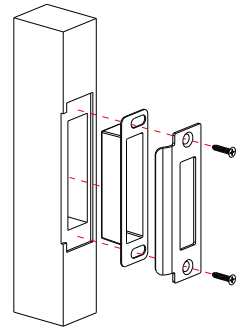

Stap 3. Boor een gat voor de sluitplaat/
sluitkast

6.2 De richting van de handgreep bepalen

De deurklink wordt bepaald op basis van de beveiligde zijde. De term 'beveiligd' betekent de zijde van waaruit u de deur in eerste instantie ontgrendelt en van buitenaf betreedt, of de scharnierzijde voor links/rechts openende deuren.

⚠ Wanneer u buiten de deur staat, kunt u de deur naar links/rechts openen en duwen/trekken om te openen, zoals weergegeven in het onderstaande diagram:

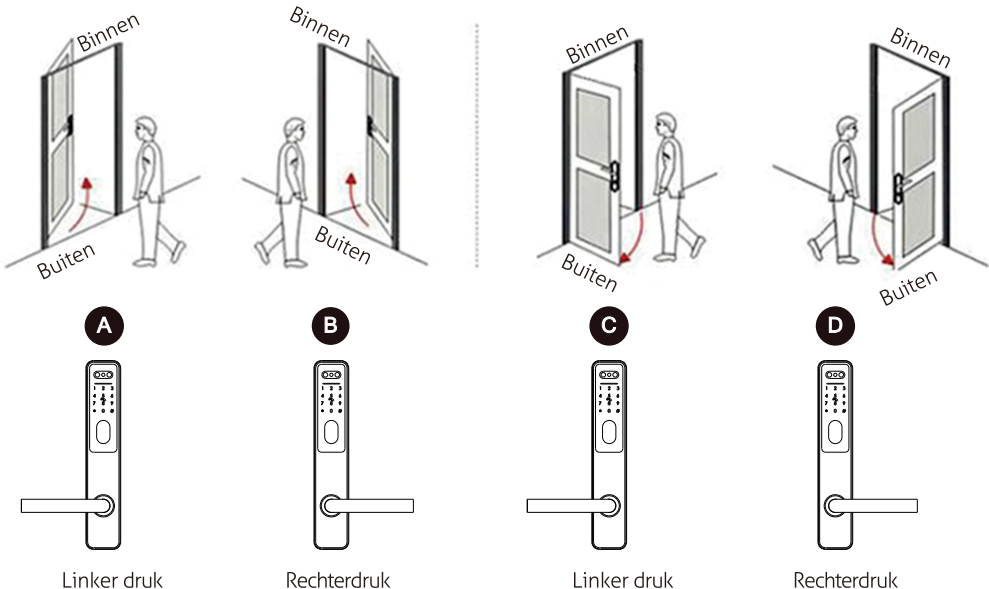

6.3 WIJZIG DE RICHTING VAN DE HANDGREEP

NL

Stel de richting van de voorste handgreep af (van rechts naar links)

6.3.1 Gebruik de inbusleutel om de schroef en de hendel te verwijderen.

6.3.2 Draai de handgreep 180 graden tegen de klok in.

6.3.3 Zodra de hendel volledig is gedraaid, plaatst u de schroef en hendel terug en draait u deze stevig vast.

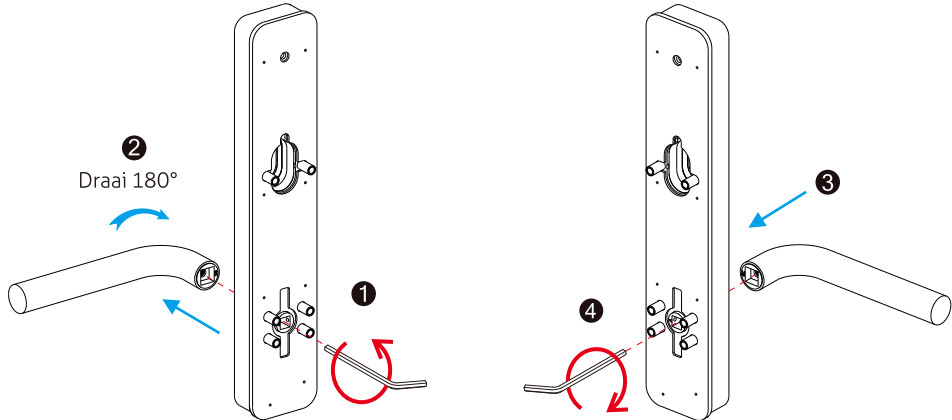

Pas de richting van de achterste handgreep aan

6.3.4 Gebruik de inbusleutel om de schroef en de hendel te verwijderen.

6.3.5 Draai de handgreep 180 graden met de klok mee.

6.3.6 Zodra de handgreep volledig is gedraaid, plaatst u de schroef en handgreep terug en draait u deze stevig vast.

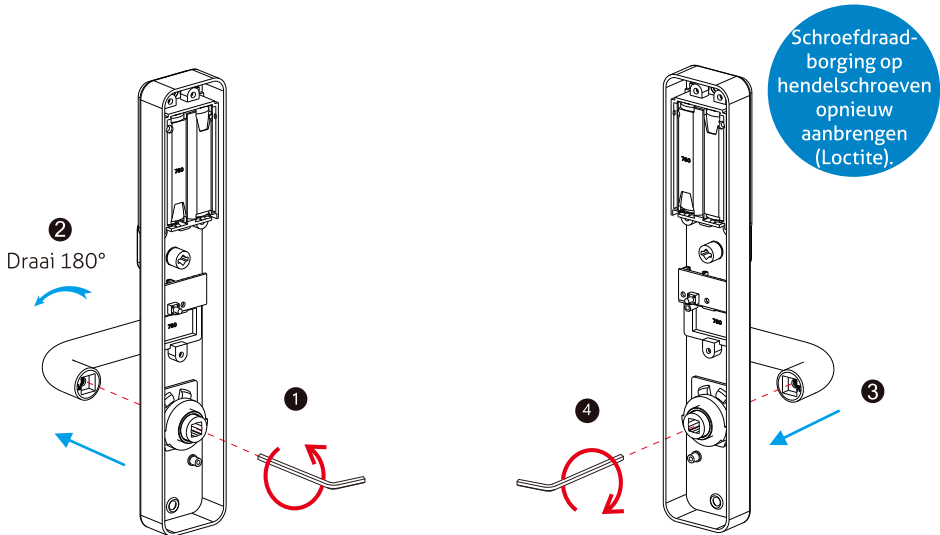

6.4 DE RICHTING VAN DE DRIEHOEKIGE PUNT VERANDEREN

STROXX

Zorg ervoor dat de richting van de driehoekige punt overeenkomt met die van de handgreep.

6.4.1 Als de handgreep naar links wijst, draai dan de driehoek naar links.

6.4.2 Als de handgreep naar rechts wijst, draait u de driehoekige punt naar rechts

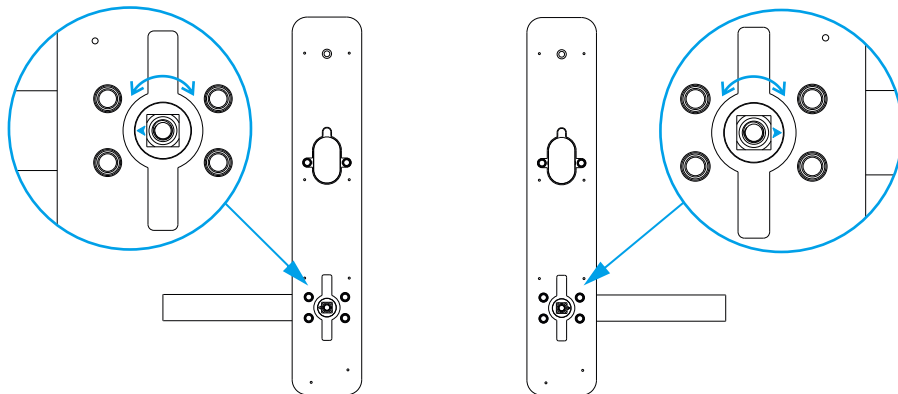

6.5 INSTALLATIE-MONTAGE

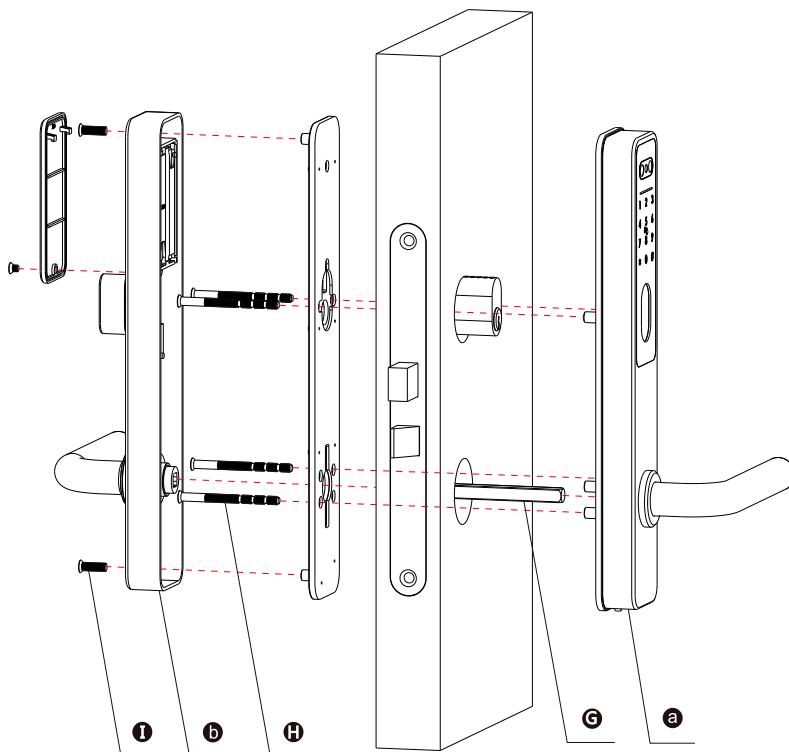

7. STAPPEN VOOR HET INSTALLEREN VAN HET SLOT

NL

7.1 Monteer de slotbeugel en cilinder

Monteer de slotbeugel en cilinder in de sleuf.

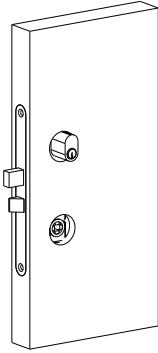

7.3 Sluit de kabel aan

7.3.1 Sluit eerst de draden aan.

7.3.2 Plaats de spindels (G) in het gat.

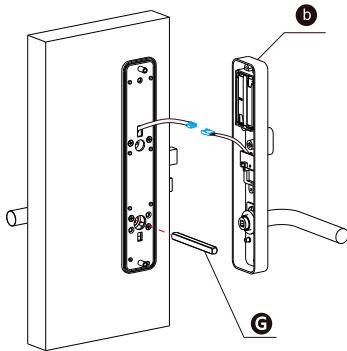

7.5 Monteer de batterijhouder

Plaats 2 x 18650-batterijen en sluit het deksel van de batterijhouder.

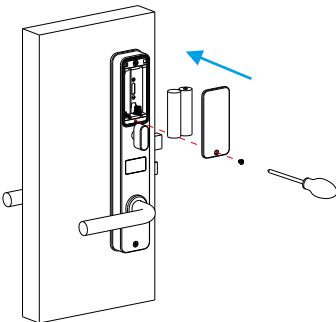

7.2 Bevestig het voorpaneel

7.2.1 Bevestig het voorpaneel (a) aan de deur en voer de kabel door het gat.

7.2.2 Verkort de schroef tot een geschikte lengte in verhouding tot de dikte van de deur.

7.2.3 Draai de schroef (H) vast aan de achterste afdekking met de magneetklep van het voorpaneel.

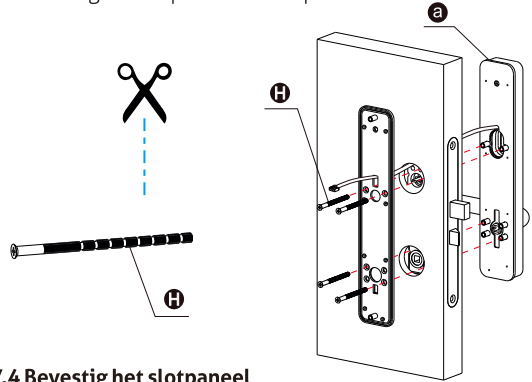

7.4 Bevestig het slotpaneel

Verwijder eerst het deksel van het batterijcompartiment en bevestig vervolgens het achterpaneel (b) met de achterafdekking met behulp van de twee schroeven (p).

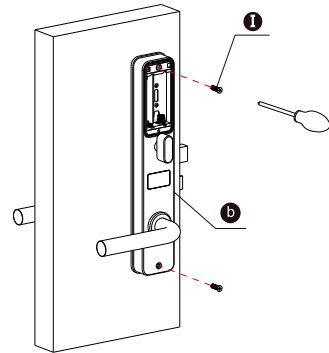

7.6 Stel het vergrendelingspaneel af

Zodra de installatie is voltooid, past u de positie van het vergrendelingspaneel of de schroeven aan als deze te strak zitten. Steek de sleutel in het slot, draai deze om en druk vervolgens op de hendel om te openen.

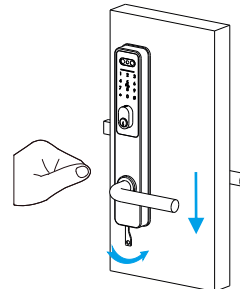

8. VOEG JE SMART LOCK TOE AAN DE XLOCK-APP

STROXX

Opmerking: Het is noodzakelijk om de nieuwe beheerder te registreren voordat u dit slot gaat gebruiken.

U kunt de onderstaande stappen volgen:



Download XLOCK uit de Apple Store of Google Play. U kunt ook de onderstaande QR-code scannen om de app rechtstreeks te downloaden.



Scan de QR-code voor
instructies voor de APP
en meer



Bluetooth



Pincode



Handmatige
sleutel



Hanpalm-
aafdruk











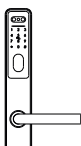
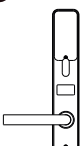

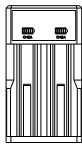
Kaart

1. ZUBEHÖR

DE

Überprüfen Sie die Verpackung und das Zubehör, wenn Sie das Schloss erhalten.

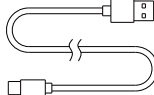
a  1 Stück Frontplatte	b  1 Stück Rückwand	c  1 Stück Bedienungsanlei- tung	d  1 Stück Inbusschlüssel	e  1 Stück Ladegerät	f  2 Stück Batterien
Türstärke Anzahl	* G 	* H 	* I 	J  2 Stück Schlüssel	K  2 Stück Karten
40-50mm	8x8x70:1	4 Stück M5X100	2 Stück M5X16	L  1 Stück Netzteil	M  1 Stück USB-Kabel
51-60mm	8x8x80:1				
61-70mm	8x8x90:1				
71-80mm	8x8x100:1				
81-90mm	8x8x110:1				
91-100mm	8x8x120:1				

2. PRODUKTÜBERSICHT

VORDERSEITE

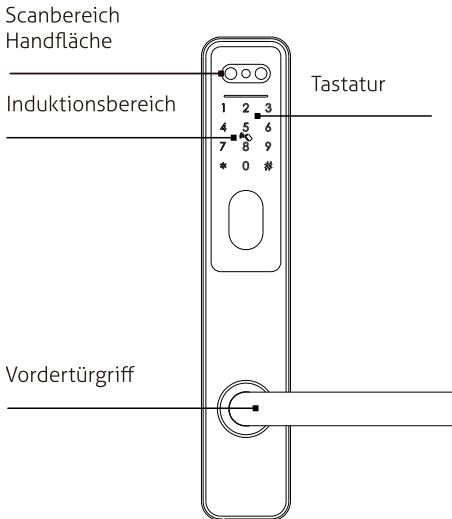

RÜCKSEITE

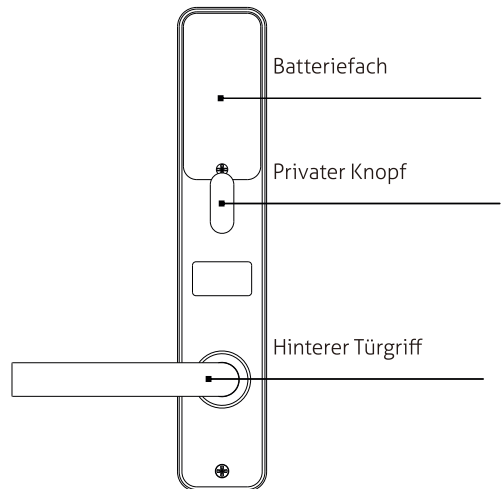

ÖFFNEN UND SCHLIESSEN

Geben Sie das gültige Passwort ein, drücken Sie die IC-Karte oder die Handflächenerkennung, um die Tür zu öffnen.

3. SYSTEMVORSTELLUNG

STROXX

Material	Edelstahl, ABS, Glas
Verfügbare Farben	Silber gebürstetes Metall / Mattschwarz
Türstärke	40–100 mm
Kommunikation	BLE5.0
Unterstützte Betriebssysteme	iOS 7.0 oder höher, Android 4.4 oder höher
Batterielebensdauer	2000-mal normales Entsperren (3 Monate)
Strom	DC 7.4 V: 2 x 18650-Batterien
Statischer Strom	< 50 µA
Dynamischer Strom	< 250 mA
Entsperren	IC-Karte, Passwort, Handabdruck, Schlüssel, APP
Sperrzeit	1–1,5 Sekunden
Betriebstemperatur	-20C°–50C° Grad
Betriebsfeuchtigkeit	10–95 %
Werkseinstellung	Werkseitiger Standard-Hauptzugangscode: 123456, nach der Konfiguration ist er ungültig
Virtueller Zugangscode	Verfügbar
Benutzerkapazität	Karte: 1.000, Passwort: 250, Handfläche: 100, 1 Administrator

4. AUF WERKSEINSTELLUNGEN ZURÜCKSETZEN



ACHTUNG

Auf der Rückseite des hinteren Bedienfelds befindet sich eine Reset-Taste. Sie können diese Taste 3 Sekunden lang drücken, während die Audioansage „Initialisierungscode eingeben“ ertönt, und dann Folgendes eingeben: 000#, woraufhin die Audioansage „Erfolgreich“ ertönt. Das Schloss befindet sich dann in den Werkseinstellungen, der Standard-Master-Zugangscode lautet: 123456

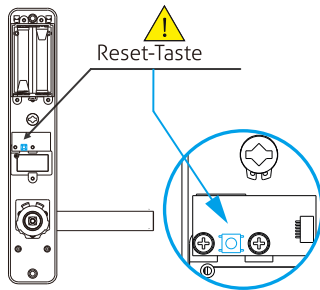

Drücken Sie 000#

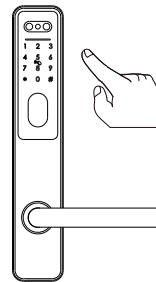

Werkseinstellung:
Master-Zugangscode:
123456

DEADLOCK-FUNKTION



ACHTUNG

Auf der Rückseite befindet sich ein privater Drehknopf. Sie können diesen Drehknopf in die verriegelte Position drehen. Beachten Sie, dass dadurch die elektronische Entriegelung außer Kraft gesetzt wird, sodass die Entriegelung nur von außen mit dem Schlüsselzylinder und anschließend durch elektronische Entriegelung erfolgen kann. Durch Drehen des Drehknopfs in die entriegelte Position funktioniert die Verriegelung wieder normal mit elektronischer Entriegelung.

Privater Drehknopf

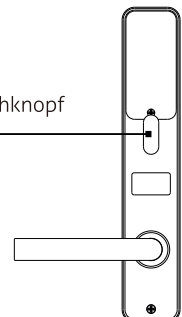

5.1 EINLEITUNG

Dieses Benutzerhandbuch führt Sie durch die Funktionen und die Verwendung unseres ST-3 Smart Lock. Es ist wichtig, dass Sie die Anweisungen befolgen und alle Hinweise in diesem Handbuch beachten. Bitte lesen Sie dieses Handbuch, bevor Sie versuchen, dieses Schloss zu verwenden. Wenn Sie Fragen haben, die in diesem Handbuch nicht beantwortet werden, oder einen nicht routinemäßigen Service benötigen, rufen Sie bitte unseren Kundendienst an oder senden Sie uns eine FAQ.

5.2 SICHERHEITSHINWEISE

Beachten Sie beim Lesen dieser Anleitung bitte die folgenden Symbole: Hinweise mit dem Symbol ⚠ (WICHTIG) müssen gelesen, verstanden und befolgt werden, um Verletzungen oder Schäden am Schloss zu vermeiden.

ALLGEMEINE VERWENDUNG ⚠

- Dieses Schloss darf nur wie in dieser Anleitung beschrieben verwendet werden.
- Überprüfen Sie, ob alle Teile des Schlosses vorhanden sind. Sollten Teile fehlen, wenden Sie sich bitte an unseren Kundendienst.
- In der Werkseinstellung ist das Schloss nach der Installation (ohne Stromversorgung) immer offen. Das bedeutet, dass der Griff frei ist und das Schloss nicht verriegelt werden kann. Sie müssen das Schloss mit Batterien einschalten oder den Administrator einrichten und das Schloss mit der App koppeln. Danach befindet sich das Schloss automatisch im privaten Modus.
- Die Richtung des Griffs kann umgekehrt werden. Bitte lesen Sie Kapitel 6, um die Richtung zu ändern, wenn die Öffnungsrichtung der Tür nicht mit Ihrem Schloss übereinstimmt. Bei Problemen wenden Sie sich bitte an unseren Servicetechniker.
- Auf dem vorderen Touchpanel befindet sich eine Schutzfolie. Wenn die Folie Kratzer aufweist, entfernen Sie sie gegebenenfalls.
- Verwenden Sie 2 x 18650-Batterien. Verwenden Sie keine alten und neuen Batterien zusammen.
- Stecken Sie niemals andere Gegenstände als die in dieser Anleitung beschriebenen Batterien in das Schloss.
- Stellen Sie vor Beginn der Installation sicher, dass alle Oberflächen eben und waagrecht sind. Die Installation an Türen oder Oberflächen mit jeglicher Art von Verformungen, wie z. B. Spalten oder Verwindungen, kann dazu führen, dass das Schloss schlecht oder gar nicht funktioniert.
- Tragen Sie niemals Reinigungsmittel direkt auf Teile dieses Schlosses auf. Verwenden Sie zum Reinigen des Schlosses nur sauberes Wasser oder ein mildes Reinigungsmittel auf einem weichen, nicht scheuernden Tuch.
- Warnung vor möglicher Stromschlaggefahr: Lassen Sie kein Wasser oder andere Flüssigkeiten in die elektrischen Teile des Schlosses eindringen.
- Das Schloss muss mit der XLOCK-App verwendet werden. Das Schloss funktioniert auch ohne die App, aber die volle Funktionalität wird nur erreicht, wenn die App verwendet wird.

5.4 BESONDERE BEACHTUNG

Denken Sie daran, die Batterie zu ersetzen, wenn der Batteriealarm aktiviert wird.

Bitte lesen Sie diese Anleitung vor der Installation sorgfältig durch und bewahren Sie sie zum späteren Nachschlagen auf.

Ihr STROXX-Händler vor Ort übernimmt die Garantie- und Reklamationsabwicklung im Namen von Stroxx in Deutschland. Sie können sich über unsere Garantiebedingungen unter folgendem Link informieren: stroxx.eu/pages/garantie-de

6. VORBEREITUNG DER INSTALLATION

STROXX

6.1 Strichzeichnung

Montieren Sie zuerst die Einsteckbeschläge, dann den Zylinder, das Schließblech und die Schließblechdose.

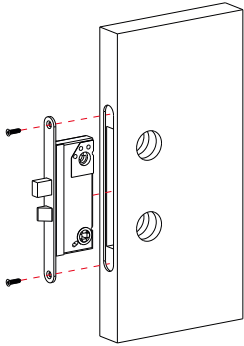

Schritt 1. Montieren Sie die Einsteckbeschläge.

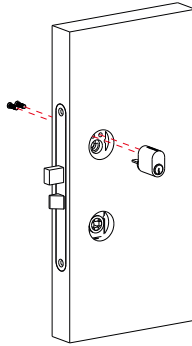

Schritt 2. Montieren Sie den Zylinder.

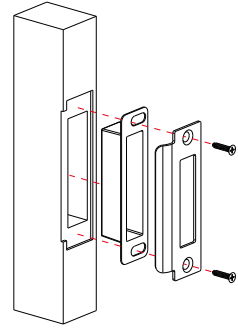

Schritt 3. Bohren Sie ein Loch für die Schließplatte/den Schließkasten.

6.2 Bestimmung der Griffrichtung

Die Türgriffseite wird anhand der sicheren Seite bestimmt. Der Begriff „sicher“ bezieht sich auf die Seite, von der aus Sie die Tür zunächst von außen entriegeln und betreten, oder auf die Scharnierseite bei links-/rechts öffnenden Türen.

⚠ Wenn Sie vor der Tür stehen, gibt es eine Öffnung nach links/rechts und eine Öffnung durch Drücken/Ziehen, wie in der folgenden Abbildung dargestellt:

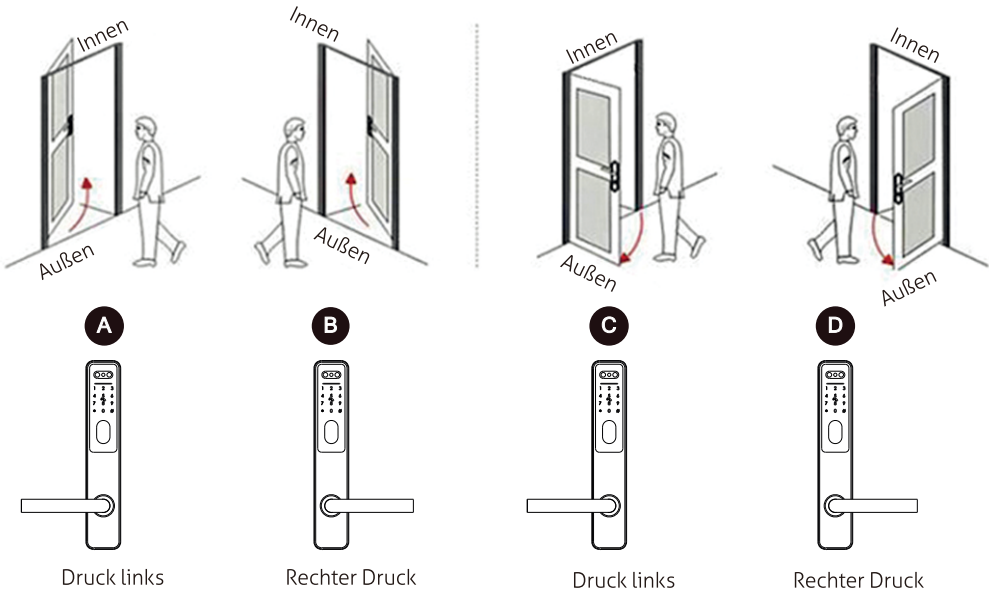

6.3 GRIFF-RICHTUNG ÄNDERN

DE

Stellen Sie die Richtung des vorderen Griffs ein (von rechts nach links).

6.3.1 Entfernen Sie die Schraube und den Griff mit dem Inbusschlüssel.

6.3.2 Drehen Sie den Griff um 180 Grad gegen den Uhrzeigersinn.

6.3.3 Sobald der Griff vollständig gedreht wurde, bringen Sie die Schraube und den Griff wieder an und ziehen Sie sie fest an.

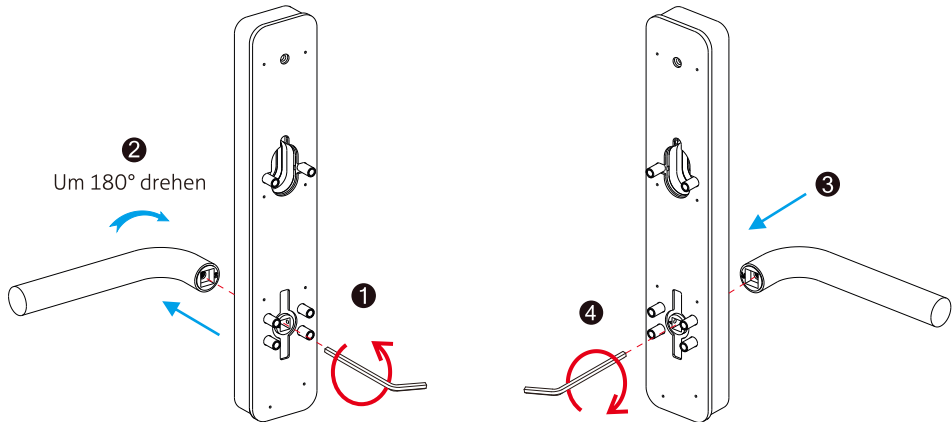

Richten Sie die Richtung des hinteren Griffs ein

6.3.4 Entfernen Sie die Schraube und den Griff mit dem Inbusschlüssel.

6.3.5 Drehen Sie den Griff um 180 Grad im Uhrzeigersinn.

6.3.6 Sobald der Griff vollständig gedreht wurde, bringen Sie die Schraube und den Griff wieder an und ziehen Sie sie fest an.

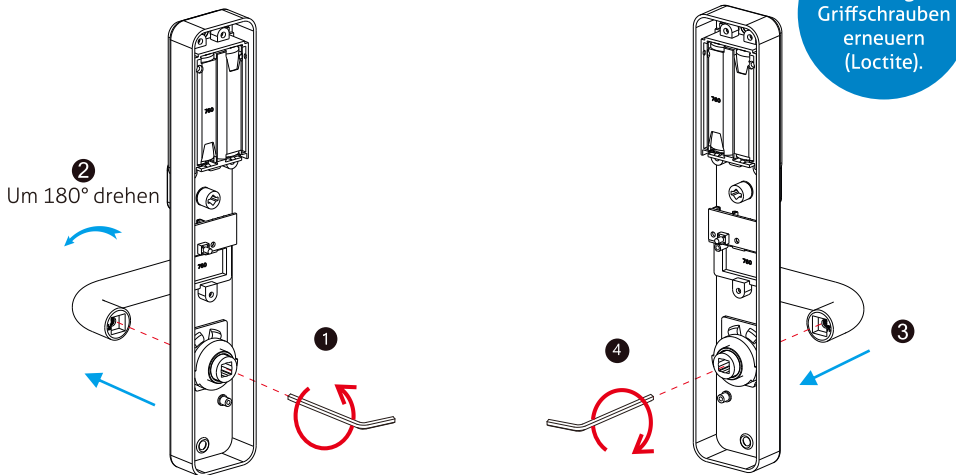

6.4 ÄNDERN SIE DIE RICHTUNG DER DREIECKIGEN SPITZE

STROXX

Stellen Sie sicher, dass die Richtung der dreieckigen Spitze mit dem Griff übereinstimmt.

6.4.1 Wenn der Griff nach links zeigt, drehen Sie die Dreieckspitze nach links.

6.4.2 Wenn der Griff nach rechts zeigt, drehen Sie die dreieckige Spitze nach rechts.

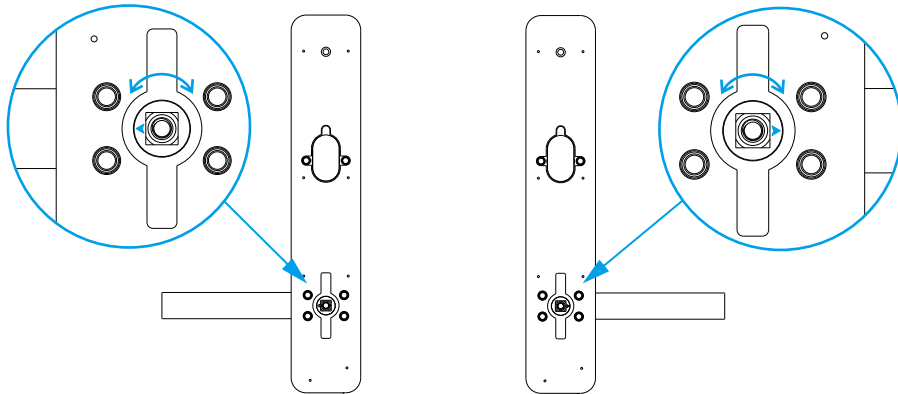

6.5 INSTALLATION-MONTAGE

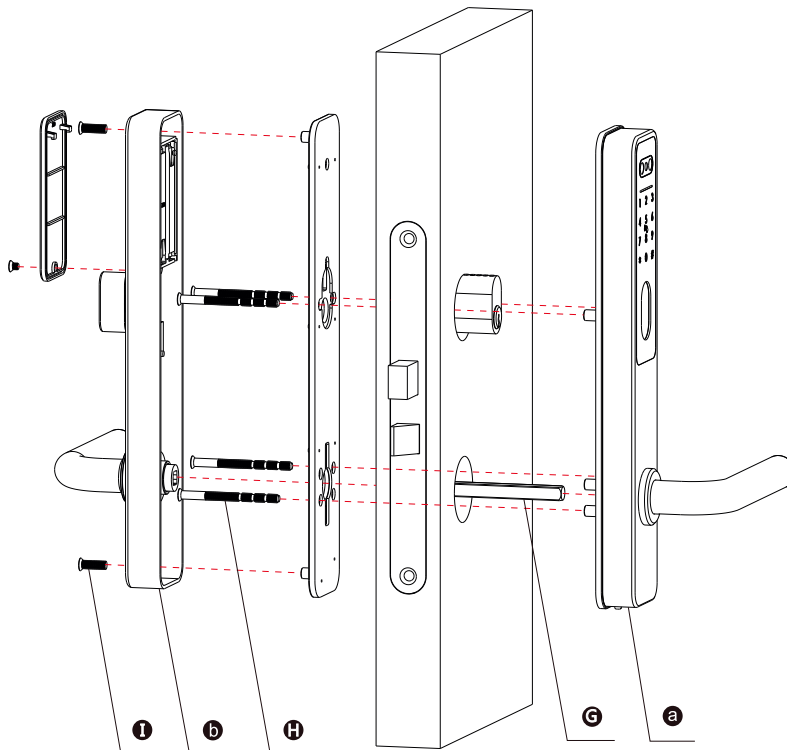

7. SCHRITTE ZUR INSTALLATION DES SCHLOSSES

DE

7.1 Montieren Sie die Schlosshalterung und den Zylinder

Montieren Sie die Schlosshalterung und den Zylinder in der Aussparung.

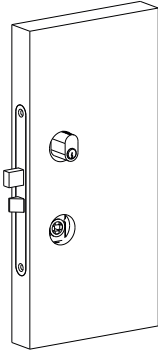

7.2 Montieren Sie die Frontplatte

7.2.1 Befestigen Sie die Frontplatte (a) an der Tür und führen Sie das Kabel durch die Öffnung.

7.2.2 Kürzen Sie die Schraube entsprechend der Dicke der Tür auf eine geeignete Länge.

7.2.3 Ziehen Sie die Schraube (H) an der hinteren Abdeckung mit dem Magnetventil der Frontblende fest.

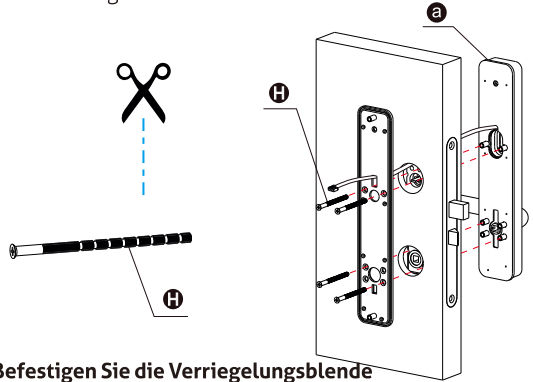

7.3 Kabel anschließen

7.3.1 Verbinden Sie zuerst die Drähte.

7.3.2 Setzen Sie die Spindeln (G) in die Bohrung ein.

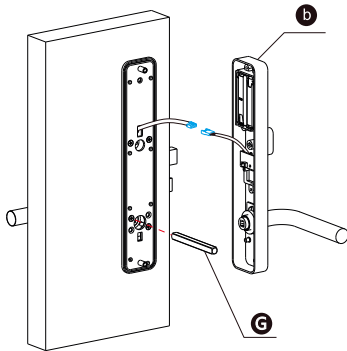

7.4 Befestigen Sie die Verriegelungsblende

Entfernen Sie zunächst die Batterieabdeckung und befestigen Sie dann die Rückwand (b) mit den beiden Schrauben (p) an der hinteren Abdeckung.

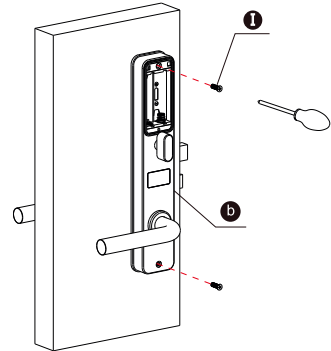

7.5 Batteriefach zusammenbauen

Legen Sie 2 x 18650-Batterien ein und verschließen Sie den Batteriefachdeckel.

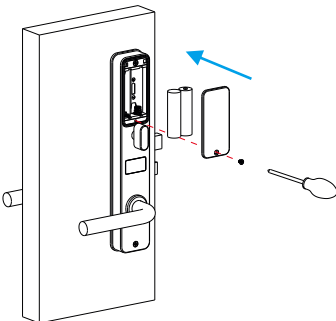

7.6 Stellen Sie die Verriegelungsplatte ein

Stellen Sie nach Abschluss der Installation die Position der Verriegelungsplatte oder der Schrauben ein, wenn diese zu fest sitzt. Stecken Sie den Schlüssel ein, drehen Sie ihn und drücken Sie dann den Griff, um die Tür zu öffnen.

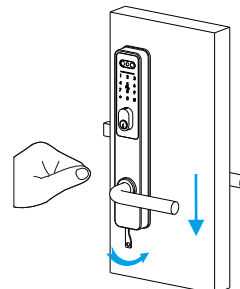

8. FÜGE DEIN SMART LOCK ZUR XLOCK-APP HINZU

Hinweis: Bevor Sie diese Sperre verwenden können, müssen Sie den neuen Administrator registrieren.

Befolgen Sie dazu die folgenden Schritte:

1 Halten Sie die Reset-Taste 3 Sekunden lang gedrückt.

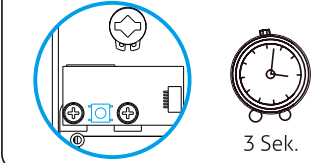

3 Sek.

2 Geben Sie den Initialisierungscode 000# ein, bis Sie die Ansage „erfolgreich“ hören.

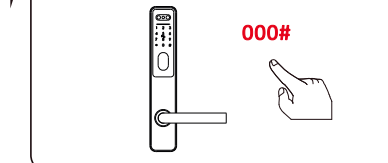

000#

Laden Sie XLOCK aus dem Apple Store oder von Google Play herunter. Sie können auch den untenstehenden QR-Code scannen, um die App direkt herunterzuladen.



Scannen Sie den QR-Code, um Anweisungen für die APP und mehr zu erhalten



Bluetooth



PIN-Code



Manueller Schlüssel



Handabdruck









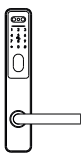
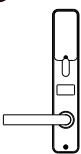

Karte

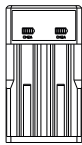
1. ACCESSOIRES

FR

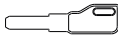
Vérifiez l'emballage et les accessoires lorsque vous recevez le cadenas.

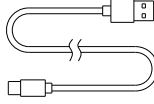
a  1 pièce Panneau avant	b  1 pièce Panneau arrière	c  1 pièce Manuel d'utilisation	d  1 pièce Allen 1clé	e  1 pièce Chargeur	f  2 pièces piles
Epaisseur de porte Nombre	* G 	* H 	* I 	J  2 pièces clé	K  2 pièces cartes
	40-50mm	8x8x70:1	4 pièces M5X100	2 pièces M5X16	L  1 adaptador de corriente
	51-60mm	8x8x80:1			
	61-70mm	8x8x90:1			
	71-80mm	8x8x100:1			
	81-90mm	8x8x110:1			
91-100mm	8x8x120:1	M  1 cable USB			

2. PRÉSENTATION DU PRODUIT

PANNEAU AVANT

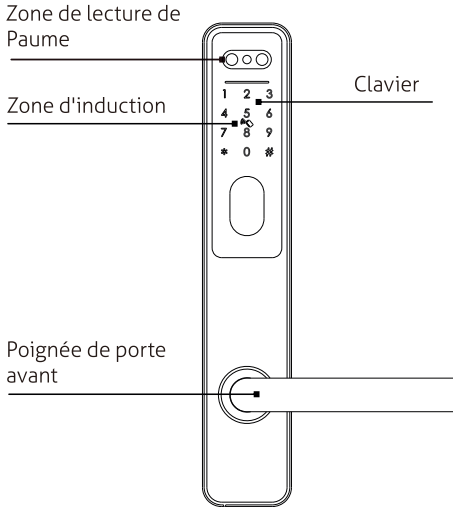

PANNEAU ARRIÈRE

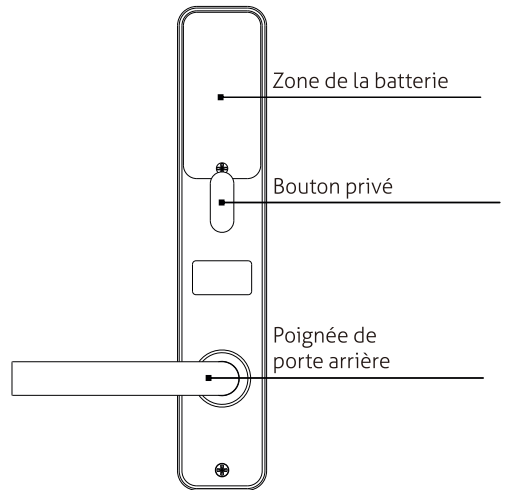

OUVERTURE ET FERMETURE

Entrez le mot de passe valide, appuyez sur la carte IC ou utilisez la reconnaissance palmaire pour ouvrir la porte.

3. PRÉSENTATION DU SYSTÈME

STROXX

Matériau	Acier inoxydable, ABS, verre
Couleurs disponibles	Métal brossé argenté / noir mat
Épaisseur de la porte	40-100 mm
Communication	BLE5.0
Système d'exploitation pris en charge	iOS 7.0 ou version ultérieure, Android 4.4 ou version ultérieure
Autonomie	2000 déverrouillages normaux (3 mois)
Alimentation	7.4 V CC : 2 piles 18650
Courant statique	< 50 uA
Courant dynamique	< 250 mA
Déverrouillage	Carte à puce, mot de passe, empreinte palmaire, clé, application
Temps de verrouillage	1 ~ 1,5 seconde
Température de fonctionnement	-20C° ~ 50C° degrés
Humidité de fonctionnement	10 ~ 95 %
Code d'usine	Code d'accès principal par défaut : 123456, il sera invalidé après la configuration
Code d'accès virtuel	Disponible
Capacité utilisateur	Carte : 1 000, mot de passe : 250, paume : 100, 1 administrateur

4. RÉINITIALISATION AUX PARAMÈTRES D'USINE

ATTENTION

Il y a un bouton de réinitialisation à l'arrière du panneau arrière. Vous pouvez appuyer sur ce bouton pendant 3 secondes lorsque le message audio « Entrez le code d'initialisation » est émis, puis entrer : 000#, et le message audio « Réussite » sera émis. Le verrou est alors réinitialisé aux paramètres d'usine, le code d'accès principal par défaut est : 123456

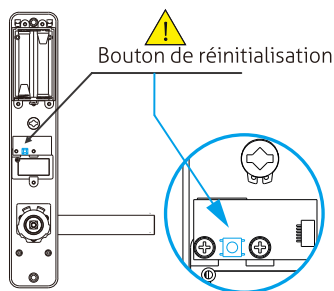

Appuyez sur 000#

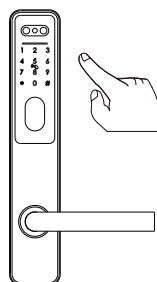

Réglage d'usine :
Code d'accès principal :
123456

FUNCTION DE VERROUILLAGE

ATTENTION

Il y a un bouton privé sur le panneau arrière. Tu peux tourner ce bouton pour le verrouiller, mais attention, ça va désactiver l'ouverture électronique, donc tu ne pourras déverrouiller que depuis l'extérieur avec la serrure à clé, puis l'ouverture électronique. En tournant le bouton pour le déverrouiller, la serrure fonctionnera à nouveau normalement avec l'ouverture électronique.

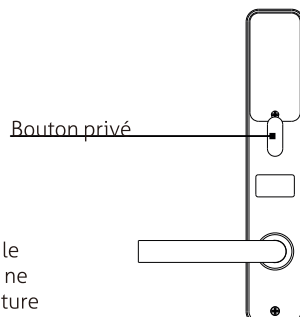

5.1 INTRODUCTION

Ce manuel d'utilisation vous guidera à travers les fonctionnalités et l'utilisation de notre serrure intelligente ST-3. Il est important que vous suiviez les instructions et que vous preniez note de tous les commentaires contenus dans ce manuel. Veuillez lire ce manuel avant d'utiliser cette serrure. Si vous avez des questions qui ne trouvent pas de réponse dans ce manuel ou si vous avez besoin d'un service hors norme, veuillez appeler notre service clientèle ou nous envoyer une FAQ.

5.2 AVERTISSEMENTS DE SÉCURITÉ

Lorsque vous lisez ce manuel, veuillez prêter attention aux icônes suivantes : Remarques accompagnées de l'icône ⚠ Doivent être lues, comprises et respectées afin d'éviter toute blessure corporelle ou tout dommage au verrou.

UTILISATION GÉNÉRALE ⚠

- Cette serrure ne doit être utilisée que conformément aux instructions fournies dans ce manuel.
- Vérifiez que toutes les pièces de la serrure sont présentes. Si des pièces manquent, veuillez contacter notre représentant du service après-vente.
- Dans les paramètres d'usine, la serrure est toujours ouverte lorsque vous l'installez (sans alimentation). Cela signifie que la poignée est libre et que la serrure ne peut pas être verrouillée. Vous devez activer la serrure à l'aide de piles ou configurer l'administrateur et coupler la serrure avec l'application, après quoi la serrure passera automatiquement en mode privé.
- Le sens de la poignée peut être inversé. Veuillez vous reporter au chapitre 6 pour modifier le sens si le sens d'ouverture de la porte ne correspond pas à celui de votre serrure. En cas de problème, veuillez contacter notre technicien de service.
- Un film protecteur recouvre le panneau tactile avant. Si le film présente des rayures, retirez-le si nécessaire.
- Utilisez 2 piles 18650. Ne mélangez pas des piles usagées et des piles neuves.
- N'insérez jamais d'autres objets que les piles décrites dans ce manuel dans la serrure.
- Assurez-vous que toutes les surfaces sont planes et horizontales avant de commencer l'installation. L'installation sur des portes ou des surfaces présentant des déformations, telles que des interstices ou des torsions, peut entraîner un mauvais fonctionnement ou un dysfonctionnement de la serrure.
- N'appliquez jamais de produits nettoyants directement sur une partie quelconque de cette serrure. Utilisez uniquement de l'eau claire ou un produit nettoyant doux sur un chiffon doux et non abrasif pour nettoyer la serrure.
- Avertissement concernant les risques d'électrocution : ne laissez pas d'eau ou de liquides pénétrer dans les parties électriques de la serrure.
- La serrure doit être utilisée avec l'application XLOCK. La serrure fonctionnera sans l'application, mais toutes ses fonctionnalités ne seront disponibles que lorsque l'application est utilisée.

5.4 SOYEZ PARTICULIÈREMENT ATTENTIF

N'oubliez pas de remplacer la pile lorsque l'alarme de pile faible se déclenche. Veuillez lire attentivement ce manuel avant l'installation et le conserver pour référence ultérieure.

Votre revendeur STROXX local gère la garantie et les réclamations au nom de Strox en Allemagne. Vous pouvez prendre connaissance de nos conditions de garantie en visitant le lien suivant : strox.eu/pages/garantie-fr

6. PRÉPARATION À L'INSTALLATION

STROXX

6.1 Schéma

Commencez par assembler la mortaise, puis le cylindre, la gâche et la boîte de gâche.

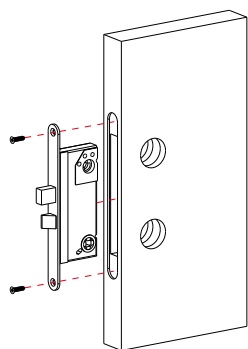

Étape 1. Assemblez la mortaise

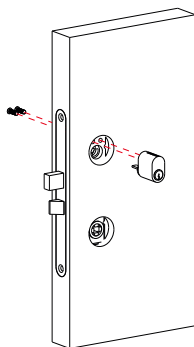

Étape 2. Assemblez le cylindre

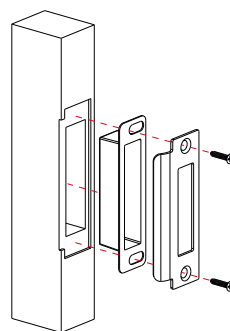

Étape 3. Percez un trou pour la gâche/boîte

6.2 Détermination du sens de la poignée

La poignée de porte est déterminée en fonction du côté sécurisé. Le terme « sécurisé » désigne le côté à partir duquel vous déverrouillez initialement la porte et entrez depuis l'extérieur, ou le côté charnière pour une ouverture à gauche/à droite.

⚠ Lorsque vous vous trouvez devant la porte, celle-ci s'ouvre vers la gauche/droite et s'ouvre en poussant/tirant, comme indiqué dans le schéma ci-dessous :

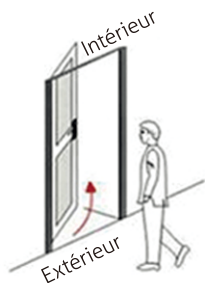

A

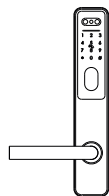

Pression gauche

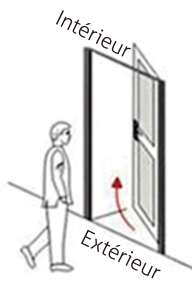

B

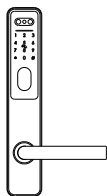

Pression à droite



C

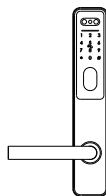

Pression gauche

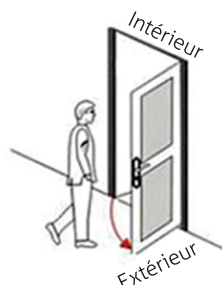

D

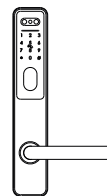

Pression à droite

6.3 CHANGER LE SENS DE LA POIGNÉE

FR

Régler la direction de la poignée avant (de droite à gauche)

6.3.1 Utilisez la clé Allen pour retirer la vis et la poignée.

6.3.2 Tournez la poignée de 180 degrés dans le sens inverse des aiguilles d'une montre.

6.3.3 Une fois la poignée tournée à fond, remettez la vis et la poignée en place et serrez fermement.

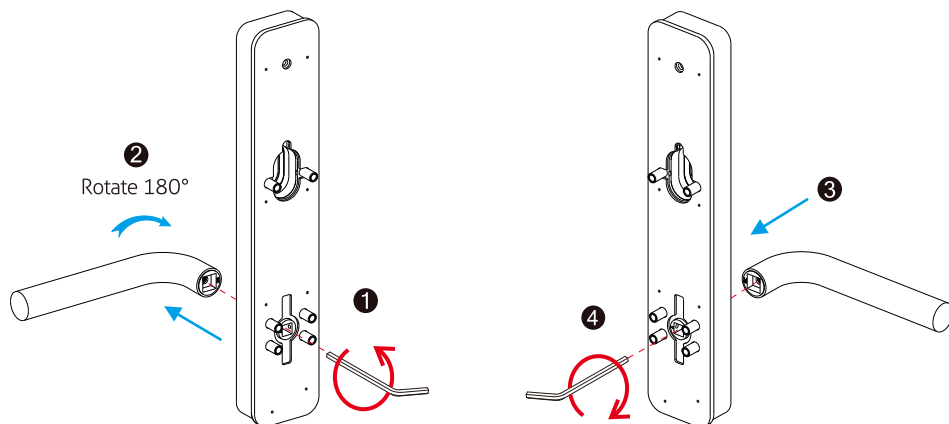

Régler la direction de la poignée arrière

6.3.4 Utilisez la clé Allen pour retirer la vis et la poignée.

6.3.5 Tournez la poignée de 180 degrés dans le sens des aiguilles d'une montre.

6.3.6 Une fois la poignée tournée à fond, remettez la vis et la poignée en place et serrez fermement.

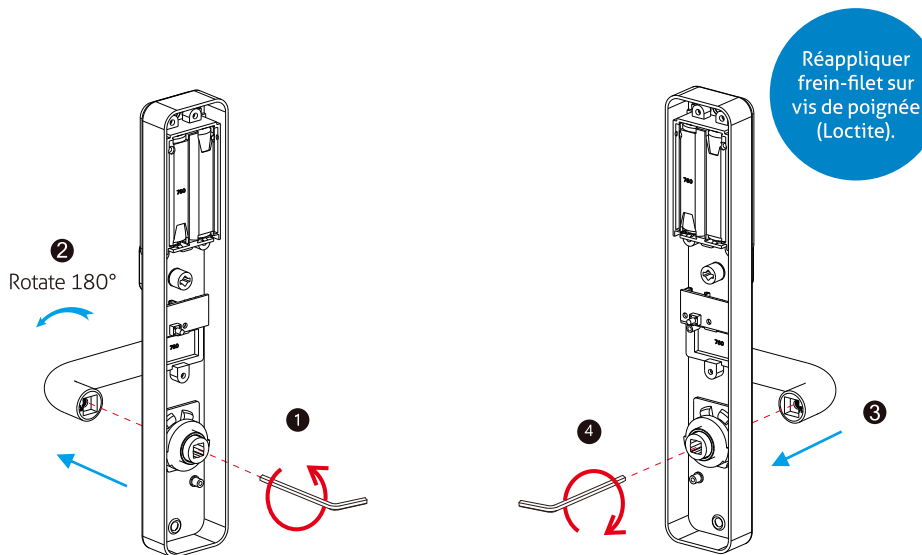

6.4 CHANGER LA DIRECTION DE LA POINTE TRIANGULAIRE

STROXX

Assurez-vous que la direction de la pointe triangulaire correspond à celle de la poignée.

6.4.1 Si la poignée pointe vers la gauche, tournez le triangle vers la gauche.

6.4.2 Si la poignée pointe vers la droite, tournez la pointe triangulaire vers la droite.

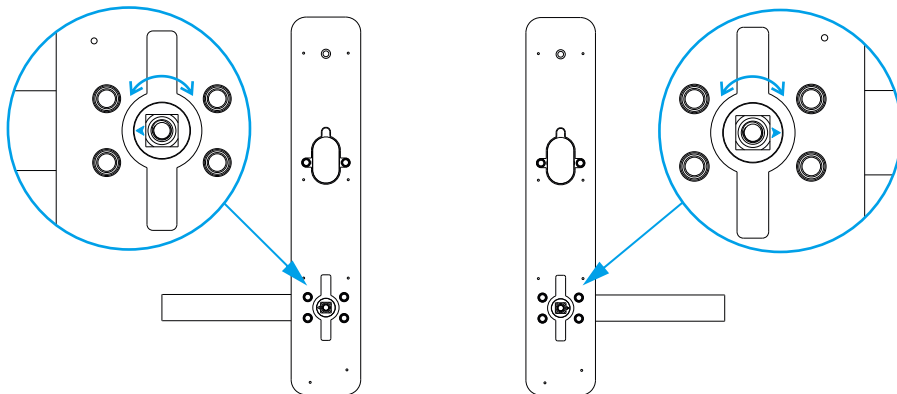

6.5 INSTALLATION-ASSEMBLAGE

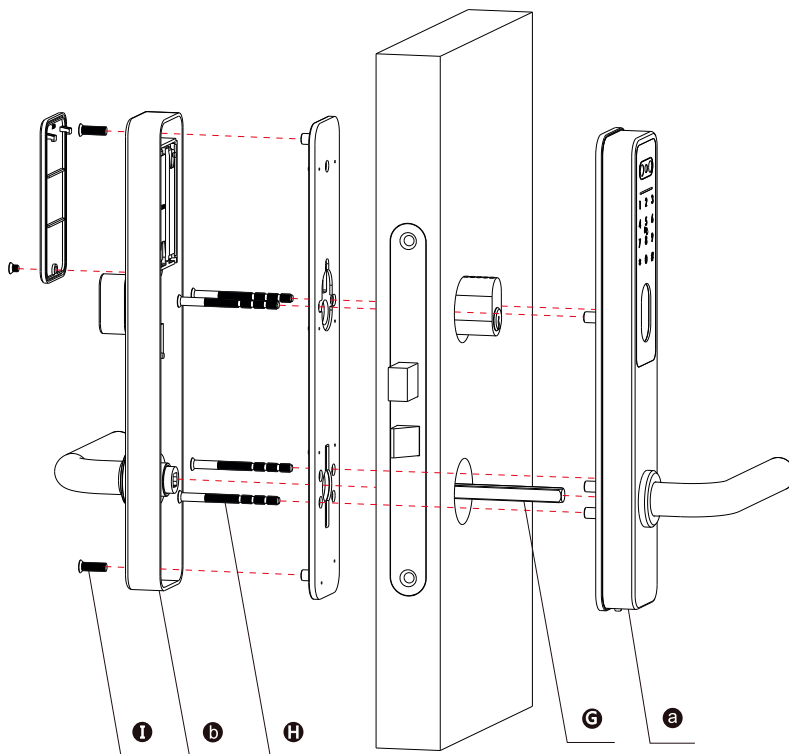

7. ÉTAPES D'INSTALLATION DE LA SERRURE

FR

7.1 Assemblez le support de serrure et le cylindre

Assemblez le support de serrure et le cylindre dans la fente.

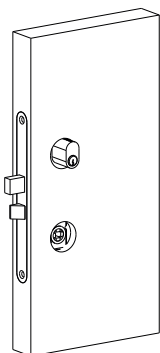

7.2 Installez le panneau avant

7.2.1 Fixez le panneau avant (a) à la porte et faites passer le câble à travers le trou.

7.2.2 Raccourcissez la vis à une longueur adaptée à l'épaisseur de la porte.

7.2.3 Serrez la vis (H) sur le couvercle arrière avec l'électrovanne du panneau avant.

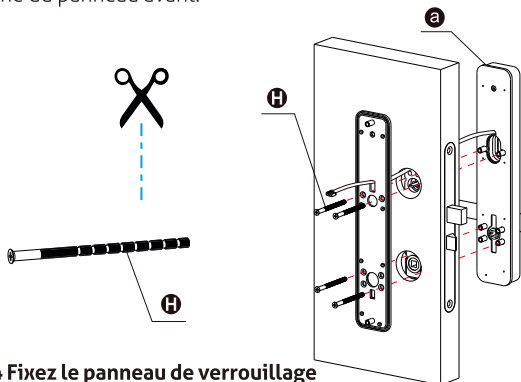

7.3 Branchez le câble

Commencez par connecter les fils. Insérez les broches (G) dans le trou.

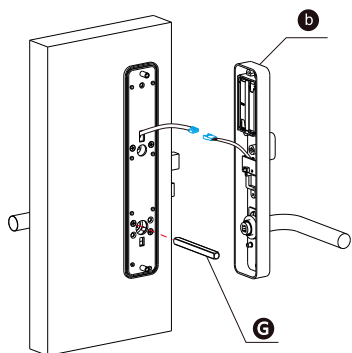

7.4 Fixez le panneau de verrouillage

Retirez d'abord le couvercle du compartiment à piles, puis fixez le panneau arrière (b) au compartiment arrière à l'aide des deux vis (p).

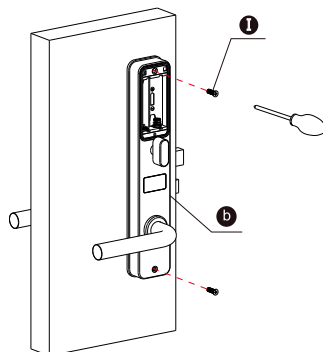

7.5 Assemblez le boîtier de batterie

Insérez 2 piles 18650 et fixez le couvercle du boîtier.

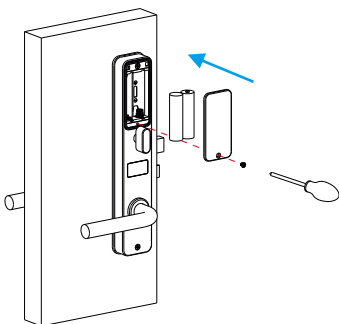

7.6 Ajustez le panneau de verrouillage

Une fois l'installation terminée, ajustez la position du panneau de verrouillage ou des vis s'il est trop serré. Insérez la clé et tournez-la, puis appuyez sur la poignée pour ouvrir.

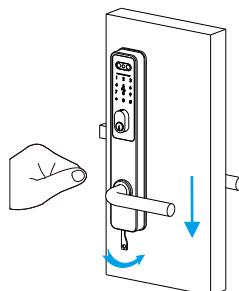

8. AJOUTEZ VOTRE SMART LOCK À L'APPLICATION XLOCK.

Remarque: il est nécessaire d'enregistrer le nouvel administrateur avant de commencer à utiliser ce verrou.

Vous pouvez suivre les étapes ci-dessous :

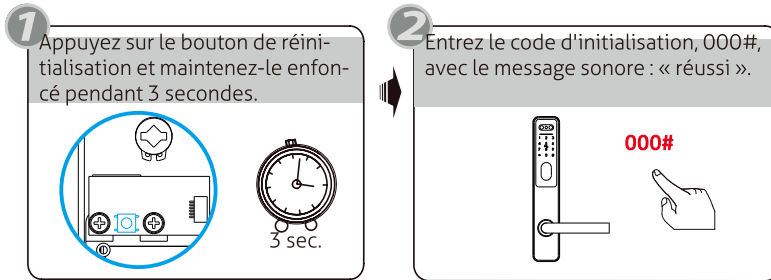

Téléchargez XLOCK depuis l'Apple Store ou Google Play. Vous pouvez également scanner le code QR ci-dessous pour télécharger directement l'application.



Scannez le code QR pour
obtenir des instructions pour
l'APP et plus encore



Bluetooth



Code PIN



Clé manuelle



Empreinte
palmaire









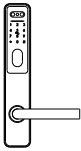
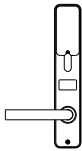

Carte

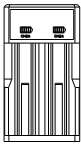
1. ACCESORIOS

ES

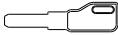
Compruebe el embalaje y los accesorios cuando reciba la cerradura.

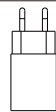
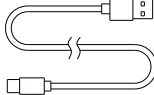
a  1 unidad Panel frontal	b  1 unidad. Panel trasero	c  1 unidad Manual de usuario	d  1 unidad Llave Allen	e  1 unidad Cargador	f  2 unidades baterías	
Espesor de la puerta Cantidad	* G 	* H 	* I 	J  2 unidades des llave	K  2 unidades tarjetas	
	40-50mm	8x8x70:1	4 unidades M5X100	2 unidades M5X16	L  1 adaptateur secteur	M  1 câble USB
	51-60mm	8x8x80:1				
	61-70mm	8x8x90:1				
	71-80mm	8x8x100:1				
	81-90mm	8x8x110:1				
91-100mm	8x8x120:1					

2. DESCRIPCIÓN GENERAL DEL PRODUCTO

PANEL FRONTAL

PANEL TRASERO

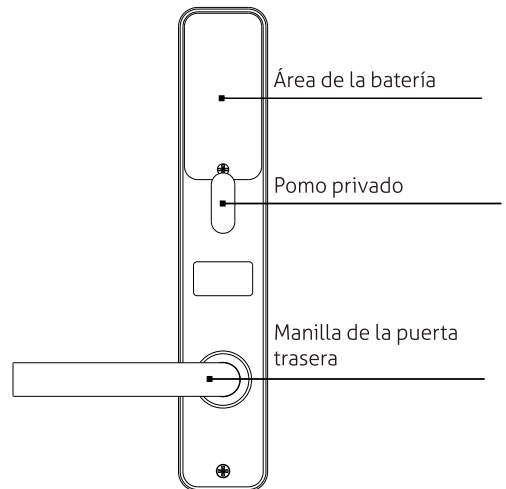
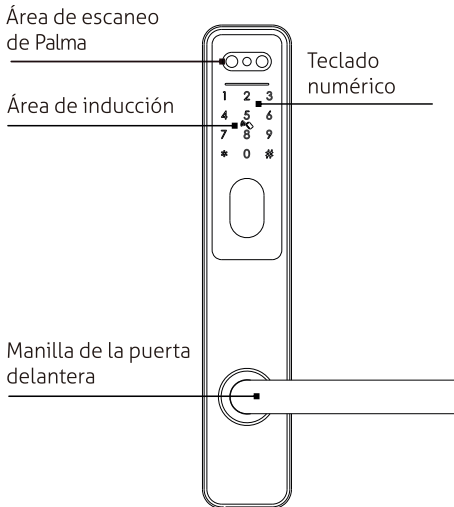

APERTURA Y CIERRE

Introduzca la contraseña válida, pulse la tarjeta IC o el reconocimiento de la palma de la mano para abrir la puerta.

3. INTRODUCCIÓN AL SISTEMA

STROXX

Material	Acero inoxidable, ABS, vidrio
Colores disponibles	Metal cepillado plateado / negro mate
Espesor de la puerta	40-100 mm
Comunicación	BLE5.0
Sistema operativo compatible	iOS 7.0 o posterior, Android 4.4 o posterior
Duración de la batería	2000 desbloques normales (3 meses)
Alimentación	7.4 V CC: 2 pilas 18650
Corriente estática	< 50 uA
Corriente dinámica	< 250 mA
Desbloqueo	Tarjeta IC, contraseña, huella palmar, llave, aplicación
Tiempo de bloqueo	1-1,5 segundos
Temperatura de funcionamiento	-20C°-50C° grados
Humedad de funcionamiento	10-95 %
Código defábrica	Código de acceso principal predeterminado de fábrica: 123456, después de la configuración dejará de ser válido
Código de acceso virtual	Disponible
Capacidad de usuarios	Tarjeta: 1000, contraseña: 250, huella: 100, 1 administrador

4. RESETEA A LA CONFIGURACIÓN DE FÁBRICA



Hay un botón de reinicio en la parte posterior del panel trasero. Puede pulsar este botón durante 3 segundos con la indicación de audio «Introduzca el código de inicialización», introduzca: 000#, con el audio: «Correcto». La cerradura quedará entonces con la configuración de fábrica, el código de acceso maestro predeterminado es: 123456

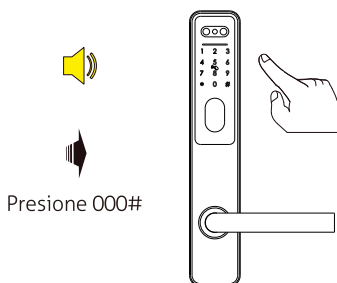
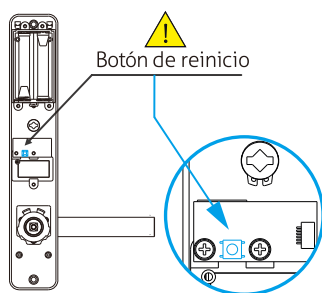

Configuración de fábrica:
Código de acceso maestro:
123456

FUNCIÓN DE BLOQUEO



Hay un interruptor privado en el panel trasero. Puede girar este interruptor a la posición de bloqueo, tenga en cuenta que esto anulará la apertura electrónica, por lo que solo se podrá desbloquear desde el exterior con el cilindro de la llave y, a continuación, la apertura electrónica. Al girar el interruptor a la posición de desbloqueo, la cerradura volverá a funcionar normalmente con la apertura electrónica.

Pomo privado

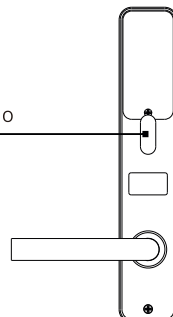

5.1 INTRODUCCIÓN

Este manual de usuario le guiará a través de las características y el uso de nuestra cerradura inteligente ST-3. Es importante que siga las instrucciones y tome nota de todos los comentarios de este manual. Lea este manual antes de intentar utilizar esta cerradura. Si tiene alguna pregunta que no se responda en este manual, o si necesita un servicio fuera de lo habitual, llame a nuestra línea de atención al cliente o envíenos una pregunta frecuente.

5.2 ADVERTENCIAS DE SEGURIDAD

Al leer este manual, preste atención a los siguientes iconos: Notas con el icono ⚠. Deben leerse, comprenderse y seguirse para evitar lesiones personales o daños a la cerradura.

USO GENERAL ⚠

- Esta cerradura solo se puede utilizar tal y como se describe en este manual.
- Compruebe que todas las piezas de la cerradura estén presentes. Si falta alguna pieza, póngase en contacto con nuestro representante de servicio técnico.
- En la configuración de fábrica, la cerradura siempre está abierta cuando se instala (sin alimentación). Esto significa que la manilla está libre y la cerradura no se puede bloquear. Debe encender la cerradura con pilas o configurar el administrador y emparejar la cerradura con la aplicación, tras lo cual la cerradura pasará automáticamente al modo privado.
- La dirección de la manija se puede invertir. Consulte el capítulo 6 para cambiar la dirección si la dirección de apertura de la puerta no es la misma que la de su cerradura. Si tiene algún problema, póngase en contacto con nuestro técnico de servicio.
- Hay una película protectora en el panel táctil frontal. Si hay arañazos en la película, retírela si es necesario.
- Utilice 2 pilas 18650. No mezcle pilas viejas y nuevas.
- Nunca introduzca ningún objeto en la cerradura que no sean las pilas descritas en este manual.
- Asegúrese de que todas las superficies estén planas y niveladas antes de comenzar la instalación. La instalación en puertas o superficies con cualquier tipo de deformación, como huecos o torceduras, puede hacer que la cerradura funcione mal o no funcione en absoluto.
- Nunca aplique productos de limpieza directamente sobre ninguna parte de esta cerradura. Utilice únicamente agua limpia o un producto de limpieza suave sobre un paño suave y no abrasivo para limpiar la cerradura.
- Advertencia de riesgo potencial de descarga eléctrica: No permita que entre agua ni líquidos en las partes eléctricas de la cerradura.
- La cerradura debe utilizarse con la aplicación XLOCK. La cerradura funcionará sin la aplicación, pero solo se logrará su plena funcionalidad cuando se utilice la aplicación.

5.4 PRESTAR ESPECIAL ATENCIÓN A

Recuerde sustituir la batería cuando se active la alarma de batería.

Lea atentamente este manual antes de la instalación y guárdelo para futuras consultas.

Su distribuidor local de STROXX se encarga de la garantía y las reclamaciones en nombre de Stroxx en Alemania. Puede consultar nuestras condiciones de garantía en el siguiente enlace: stroxx.eu/pages/warranty-es

6. PREPARACIÓN PARA LA INSTALACIÓN

STROXX

6.1 Dibujo lineal

Primero monte la mortaja, luego el cilindro, la placa de cierre y la caja de cierre.

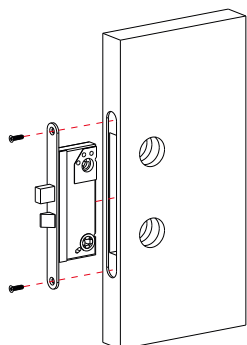

Paso 1. Ensamble la mortaja.

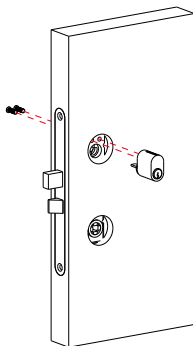

Paso 2. Ensamble el cilindro.

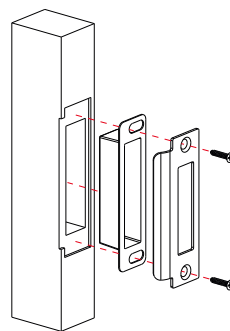

Paso 3. Taladre el orificio para la placa/ caja de cierre.

6.2 Determinación de la dirección de la manilla

La manilla de la puerta se determina en función del lado seguro. El término «seguro» se refiere al lado desde el que se abre inicialmente la puerta y se entra desde el exterior, o al lado de las bisagras para puertas que se abren hacia la izquierda o hacia la derecha.

⚠ Cuando se está fuera de la puerta, hay una apertura hacia la izquierda/derecha y hay que empujar/tirar para abrir, como se muestra en el siguiente diagrama:

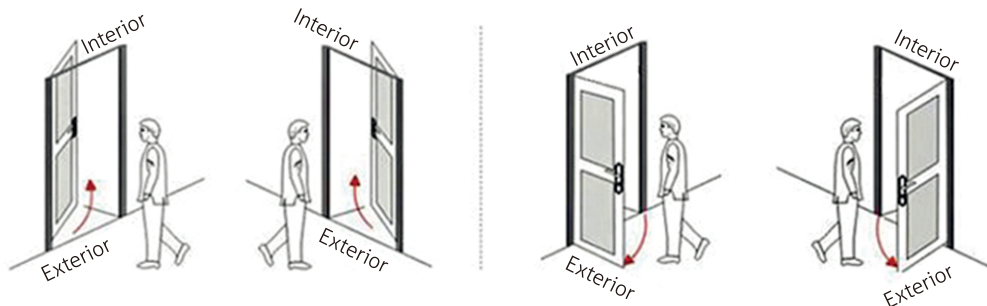

Presión izquierda

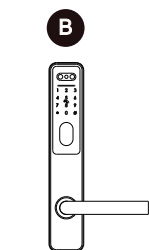

Presión derecha

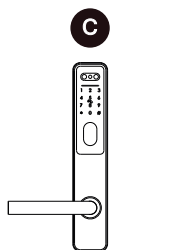

Presión izquierda

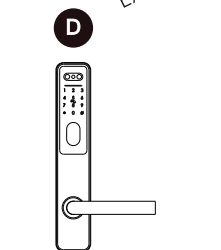

Presión derecha

6.3 CAMBIAR LA DIRECCIÓN DE LA MANGO

ES

Ajuste la dirección del mango delantero (de derecha a izquierda)

6.3.1 Utilice la llave Allen para retirar el tornillo y la manija.

6.3.2 Gire la manija 180 grados en sentido antihorario.

6.3.3 Una vez que haya girado completamente el mango, vuelva a colocar el tornillo y el mango y apriételos firmemente.

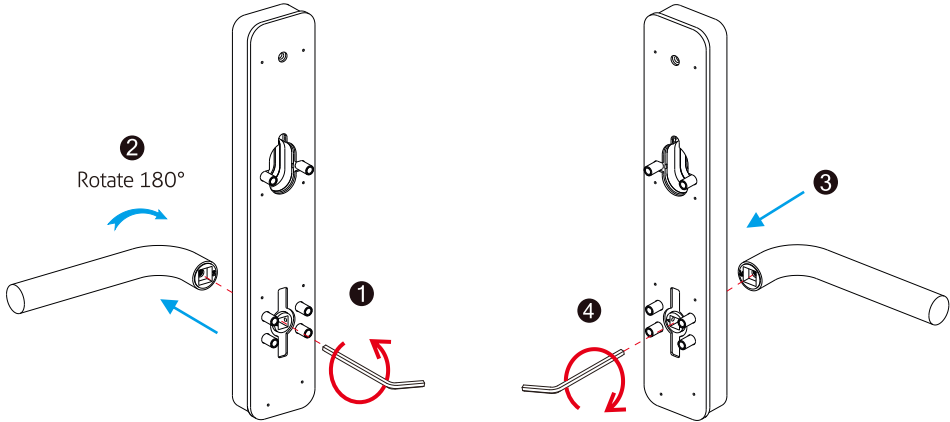

Ajuste la dirección del mango trasero

6.3.4 Utilice la llave Allen para retirar el tornillo y el mango.

6.3.5 Gire el mango 180 grados en el sentido de las agujas del reloj.

6.3.6 Una vez que la manija haya girado completamente, vuelva a colocar el tornillo y la manija y apriete firmemente.

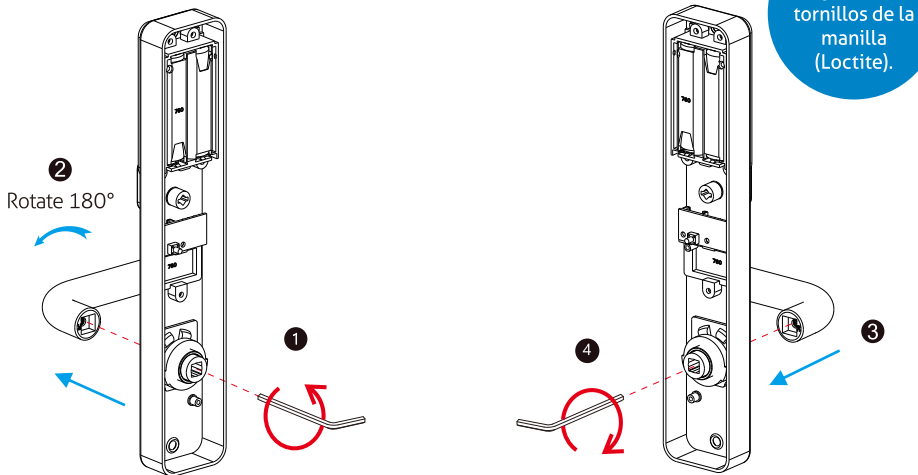

6.4 CAMBIAR LA DIRECCIÓN DE LA PUNTA TRIANGULAR **STROXX**

Asegúrese de que la dirección de la punta triangular coincida con el mango.

6.4.1 Si el mango apunta hacia la izquierda, gire el triángulo hacia la izquierda.

6.4.2 Si el mango apunta hacia la derecha, gire la punta triangular hacia la derecha.

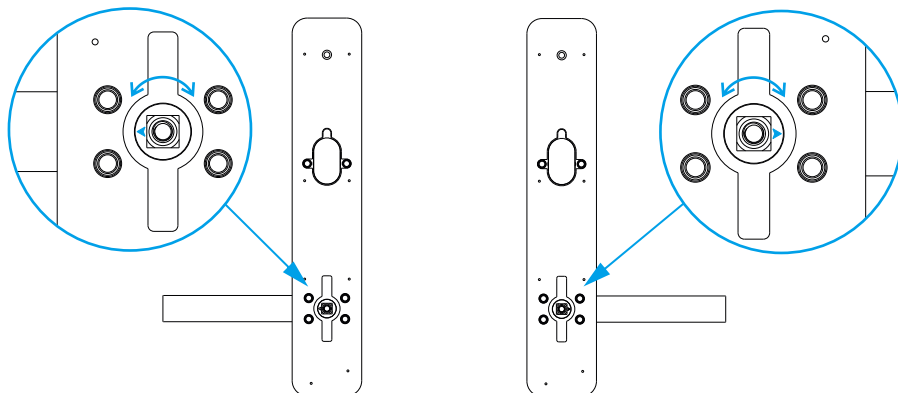

6.5 INSTALACIÓN-MONTAJE

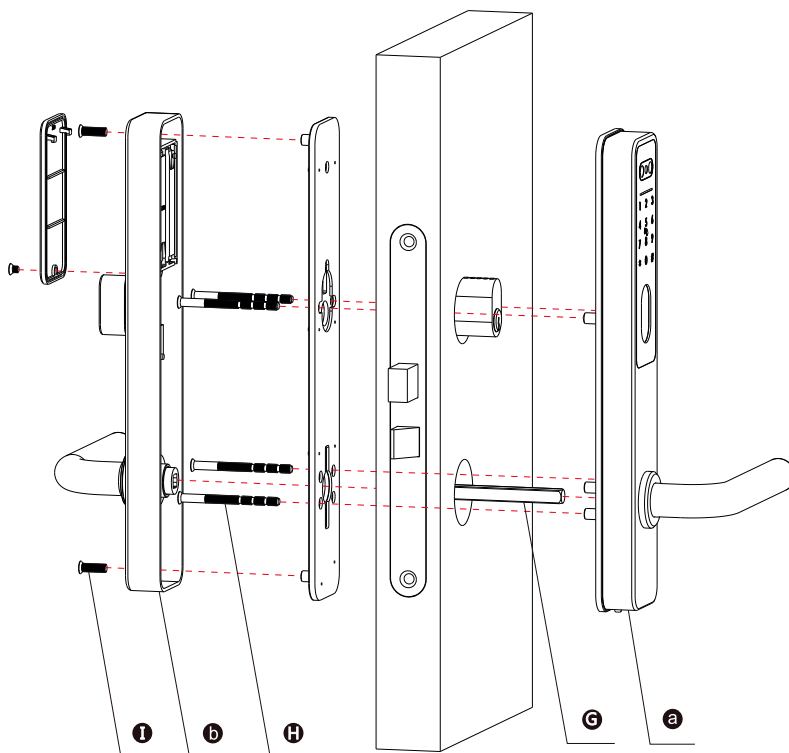

7. PASOS PARA INSTALAR LA CERRADURA

ES

7.1 Monte el soporte de la cerradura y el cilindro

Monte el soporte de la cerradura y el cilindro en la ranura.

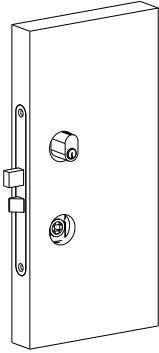

7.2 Coloque el panel frontal

7.2.1 Fije el panel frontal (a) a la puerta y pase el cable por el orificio.

7.2.2 Acorta el tornillo a una longitud adecuada en función del grosor de la puerta.

7.2.3 Apriete el tornillo (H) a la cubierta trasera con la válvula solenoide del panel frontal.

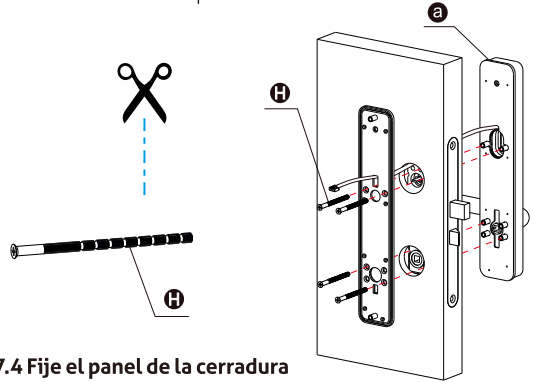

7.3 Conecte el cable

7.3.1 Conecte primero los cables.

7.3.2 Inserte los ejes (G) en el orificio.

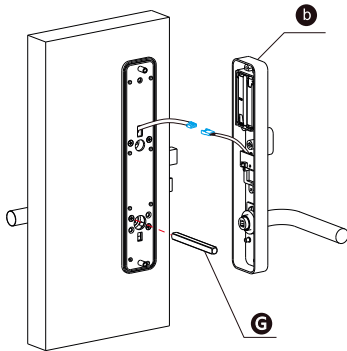

7.4 Fije el panel de la cerradura

Primero retire la tapa del compartimento de la batería y, a continuación, fije el panel trasero (b) con la cubierta trasera utilizando los dos tornillos (p).

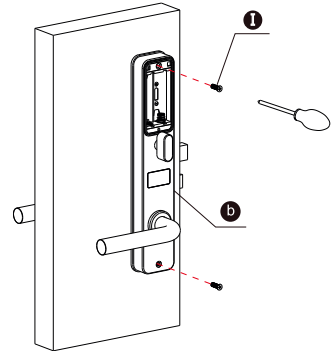

7.5 Monte la caja de la batería

Inserte 2 baterías 18650 y fije la tapa de la caja de baterías.

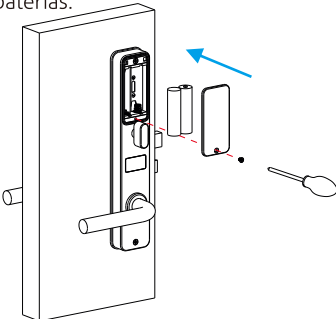

7.6 Ajuste el panel de bloqueo

Una vez completada la instalación, ajuste la posición del panel de bloqueo o los tornillos si está demasiado apretado. Inserte la llave y gírela, luego presione la manija para abrir.

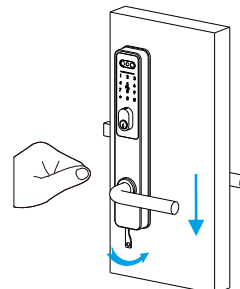

8. AÑADE TU SMART LOCK A LA APLICACIÓN XLOCK.

STROXX

Nota: Es necesario registrar al nuevo administrador antes de empezar a utilizar este bloqueo.

Puede seguir los pasos que se indican a continuación:

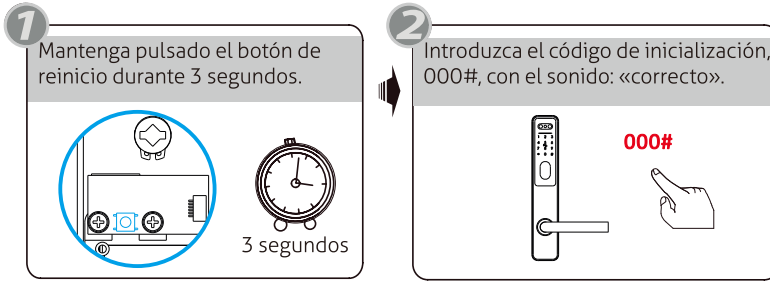

Descargue XLOCK desde Apple Store o Google Play. También puede escanear el código QR que aparece a continuación para descargar la aplicación directamente.



Escanee el código QR para obtener instrucciones sobre la aplicación y mucho más.

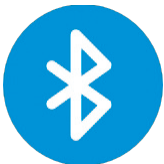

Bluetooth



Código PIN



Llave manual



Huella palmar



Tarjeta



Made in China

Union Euro Trading GmbH
Hermann-Buck-Weg 11-17
22309 Hamburg, Germany.
E-mail: info@union-euro-trading.eu



www.stroxx.eu