



# TJEP HC-18B

**Tool specification, application and declaration of conformity**

**Explode drawing and spare part list**

EN	DA	DE	ES
FI	FR	GR	HR
IT	NL	NO	PL
RO	SE	SK	SL

<b>EN</b>	Tool specification, application and declaration of conformity .....	3
<b>UK</b>	Tool specification, application and declaration of conformity (UKCA) .....	3
<b>DA</b>	Værktøjsspecifikation, anvendelse af værktøj og overensstemmelseserklæring.....	4
<b>DE</b>	Werkzeugspezifikation, einsatzbereiche des Werkzeugs und Konformitätserklärung.....	4
<b>ES</b>	Especificación de la herramienta, aplicación de la herramienta y declaración de conformidad .....	5
<b>FI</b>	Työkalun tiedot, työkalun käyttökohteet ja vaatimustenmukaisuusvakuutus .....	5
<b>FR</b>	Spécification de l'outil, application de l'outil et déclaration de conformité .....	6
<b>GR</b>	Προδιαγραφές εργαλείου, Εφαρμογή εργαλείου και Δήλωση συμμόρφωσης .....	6
<b>HR</b>	Specifikacija alata, primjena alata i izjava o sukladnosti .....	7
<b>IT</b>	Specifiche dell'utensile, applicazioni dell'utensile e dichiarazione di conformità .....	7
	<b>Explode drawing – TJEP HC-18B.....</b>	<b>8</b>
	<b>Spare part list – TJEP HC-18B.....</b>	<b>10</b>
<b>NL</b>	Technische specificaties, gebruik van het gereedschap en verklaring van overeenstemming.....	12
<b>NO</b>	Tekniske spesifikasjoner, verktøybruk og samsvarserklæring .....	12
<b>PL</b>	Specyfikacja narzędzia, zastosowanie narzędzia lub deklaracja zgodności.....	13
<b>RO</b>	Specificațiile uneltei, aplicația uneltei și declarația de conformitate.....	13
<b>SE</b>	Vektygsspecifikation, verktygstillämpning och försäkran om överensstämmelse.....	14
<b>SK</b>	Technické špecifikácie, použitie nástroja a vyhlásenie o zhode .....	14
<b>SL</b>	Tehnične specifikacije, uporaba za orodja in izjava o skladnosti .....	15

**Tool specification**

Model	TJEP HC-18B
TJEP no.	103320
Length	418 mm
Width	113 mm
Height	305 mm
Weight	7.25 kg
Cutting capacity	Φ 5 - 18 mm
Material tensile strength	400-500 MPa
Cutting speed	3 - 5 seconds
Head rotation	360°
Power supply	Battery
Motor	18 V
L <sub>PA</sub>	73.15 dB
L <sub>WA</sub>	81.15 dB
Uncertainty (L <sub>PA</sub> /L <sub>WA</sub> )	3.0 dB
<sup>a</sup> hwz	2.274 m/s <sup>2</sup>
Uncertainty ( <sup>a</sup> hwz)	1.50 m/s <sup>2</sup>

As we are constantly developing and improving our tools, the information in this overview is subject to change without notice. Updated information can be found at [www.tjep.eu](http://www.tjep.eu)

**Tool application**

- For cutting re-bars, carbon steel, hot-rolled round steel etc.

**Accessories**

Description	Description
TJEP UniKIT Battery, 18V 4,0 Ah	Blades
TJEP UniKIT Charger	

**Declaration of conformity**

We;  
Taizhou Xindalu Electronic Technology Co., Ltd, No. 33, Chenguang Road, Eastern New Center, Wenling, Zhejiang, China

declare under our sole responsibility that the;  
TJEP HC-18B

conforms with the directive(s), its amendment(s) and standard(s); 2011/65/EU, 2006/42/EC, 2014/30/EU, 2012/19/EC, EN 62841-1:2015/A11:2022, EN 62841-2-8:2016, EN IEC 55014-1:2021, EN IEC 55014-2:2021, (add. for Charger) 2014/35/EU, EN 55014-1:2017 / EN 55014-1:2017 +A11:2020, EN 61000-3-2:2014 Class A, EN IEC 61000-3-2:2019 +A1:2021 Class A, EN 61000-3-3:2013, EN 61000-3-3:2013 +A2:2021, EN 55014-2:1997 +A1:2001 +A2:2008 Category II, (add. for Battery Pack) EN 62133-2:2017+A1:2021

Authorized contact in EU to compile the Technical File;  
KYOCERA UNIMERCO Fastening A/S, Drejervej 2, DK-7451 Sunds, Tel: +45 97 14 14 40, Mr. Ebbe Hornstrup

Serial number can be found on the front page.

Date; 11.06.2023



Shoufu XIE  
Manager, Taizhou Xindalu Electronic Technology Co., Ltd,  
Zhejiang, China

**Tool specification**

Model	TJEP HC-18B
TJEP no.	103320
Length	418 mm
Width	113 mm
Height	305 mm
Weight	7.25 kg
Cutting capacity	Φ 5 - 18 mm
Material tensile strength	400-500 MPa
Cutting speed	3 - 5 seconds
Head rotation	360°
Power supply	Battery
Motor	18 V
L <sub>PA</sub>	73.15 dB
L <sub>WA</sub>	81.15 dB
Uncertainty (L <sub>PA</sub> /L <sub>WA</sub> )	3.0 dB
<sup>a</sup> hwz	2.274 m/s <sup>2</sup>
Uncertainty ( <sup>a</sup> hwz)	1.50 m/s <sup>2</sup>

As we are constantly developing and improving our tools, the information in this overview is subject to change without notice. Updated information can be found at [www.tjep.eu](http://www.tjep.eu)

**Tool application**

- For cutting re-bars, carbon steel, hot-rolled round steel etc.

**Accessories**

Description	Description
TJEP UniKIT Battery, 18V 4,0 Ah	Blades
TJEP UniKIT Charger	

**Declaration of conformity**

We;  
Taizhou Xindalu Electronic Technology Co., Ltd, No. 33, Chenguang Road, Eastern New Center, Wenling, Zhejiang, China

declare under our sole responsibility that the;  
TJEP HC-18B

conforms with the directive(s), its amendment(s) and standard(s); 2011/65/EU, 2006/42/EC, 2014/30/EU, 2012/19/EC, EN 62841-1:2015/A11:2022, EN 62841-2-8:2016, EN IEC 55014-1:2021, EN IEC 55014-2:2021, (add. for Charger) 2014/35/EU, EN 55014-1:2017 / EN 55014-1:2017 +A11:2020, EN 61000-3-2:2014 Class A, EN IEC 61000-3-2:2019 +A1:2021 Class A, EN 61000-3-3:2013, EN 61000-3-3:2013 +A2:2021, EN 55014-2:1997 +A1:2001 +A2:2008 Category II, (add. for Battery Pack) EN 62133-2:2017+A1:2021

UK importer;  
KYOCERA UNIMERCO Tooling Ltd., Nanscawen Road, Fradley, UK-Staffordshire WS13 8LH, Tel.: +44 (0)1543 267 777, Mr. Ebbe Hornstrup

Serial number can be found on the front page.

Date; 11.06.2023



Shoufu XIE  
Manager, Taizhou Xindalu Electronic Technology Co., Ltd,  
Zhejiang, China

**Værktøjsspecifikation**

Model	TJEP HC-18B
TJEP nr.	103320
Længde	418 mm
Bredde	113 mm
Højde	305 mm
Vægt	7,25 kg
Klippekapacitet	Φ 5 - 18 mm
Materialets trækstyrke	400-500 MPa
Klippehastighed	3 - 5 sekunder
Rotation af hovedet	360°
Strømforsyning	Batteri
Motor	18 V
L <sub>PA</sub>	73,15 dB
L <sub>WA</sub>	81,15 dB
Usikkerhed (L <sub>PA</sub> /L <sub>WA</sub> )	3,0 dB
<sup>a</sup> hwz	2,274 m/s <sup>2</sup>
Usikkerhed ( <sup>a</sup> hwz)	1,50 m/s <sup>2</sup>

Da vi konstant udvikler og forbedrer vores værktøjer, kan oplysningerne i denne oversigt ændres uden varsel. Opdaterede oplysninger kan findes på [www.tjep.dk](http://www.tjep.dk)

**Anvendelse af værktøj**

- Klipping af armeringsjern, kulstoftål, varmvalset rundstål osv.

**Tilbehør**

Beskrivelse	Beskrivelse
TJEP UniKIT Batteri, 18V 4,0 Ah	Knive
TJEP UniKIT-oplader	

**Overensstemmelseserklæring**

Undertegnede:  
Taizhou Xindalu Electronic Technology Co., Ltd, No. 33, Chengu-ang Road, Eastern New Center, Wenling, Zhejiang, Kina

erklærer på eget ansvar, at  
TJEP HC-18B

er i overensstemmelse med direktivet(erne), dets ændring(er) og standarden(erne):  
2011/65/EU, 2006/42/EC, 2014/30/EU, 2012/19/EC, EN 62841-1:2015/A11:2022, EN 62841-2-8:2016, EN IEC 55014-1:2021, EN IEC 55014-2:2021, (tillæg for lader) 2014/35/EU, EN 55014-1:2017 / EN 55014-1:2017 +A11:2020, EN 61000-3-2:2014 Klasse A, EN IEC 61000-3-2:2019 +A1:2021 Klasse A, EN 61000-3-3:2013, EN 61000-3-3:2013 +A2:2021, EN 55014-2:1997 +A1:2001 +A2:2008 Kategori II, (tillæg for batteri) EN 62133-2:2017+A1:2021

Autoriseret kontakt i EU til at udarbejde den tekniske dossier;  
KYOCERA UNIMERCO Fastening A/S, Drejervej 2, DK-7451 Sunds, Tlf: +45 97 14 14 40, hr. Ebbe Hornstrup

Serienummeret findes på forsiden.

Dato: 06.11.2023



Shoufu XIE  
Leder, Taizhou Xindalu Electronic Technology Co., Ltd, Zhejiang, Kina

**Werkzeugspezifikation**

Modell	TJEP HC-18B
Artikel Nr.	103320
Länge	418 mm
Breite	113 mm
Höhe	305 mm
Gewicht	7,25 kg
Schnittleistung	Φ 5 - 18 mm
Zugfestigkeit des Materials	400-500 MPa
Schnittgeschwindigkeit	3 - 5 Sekunden
Drehung des Werkzeugkopfs	360°
Stromversorgung	Batterie
Motor	18 V
L <sub>PA</sub>	73,15 dB
L <sub>WA</sub>	81,15 dB
Unschärfe (L <sub>PA</sub> /L <sub>WA</sub> )	3,0 dB
<sup>a</sup> hwz	2,274 m/s <sup>2</sup>
Unschärfe ( <sup>a</sup> hwz)	1,50 m/s <sup>2</sup>

Da wir unsere Werkzeuge ständig weiterentwickeln und verbessern, behalten wir uns Änderungen an den in dieser Übersicht angezeigten Informationen ohne vorherige Ankündigung vor. Informationen auf dem neuesten Stand finden Sie auf [www.tjep.de](http://www.tjep.de)

**Einsatzbereiche des Werkzeugs**

- Zum Schneiden von Betonarmierungen, Kohlenstoffstahl, warmgewalztem Rundstahl und dergleichen

**Zubehör**

Beschreibung	Beschreibung
TJEP UniKIT Akku, 18 V 4,0 Ah	Messerblock
TJEP UniKIT-Ladegerät	

**Konformitätserklæring**

Wir;  
Taizhou Xindalu Electronic Technology Co., Ltd, Nr. 33, Chengu-ang Road, Eastern New Center, Wenling, Zhejiang, China  
erklären in alleiniger Verantwortung, dass die  
TJEP HC-18B

den folgenden Richtlinien und Normen in ihrer jeweils gültigen Fassung entspricht;  
2011/65/EU, 2006/42/EC, 2014/30/EU, 2012/19/EC, EN 62841-1:2015/A11:2022, EN 62841-2-8:2016, EN IEC 55014-1:2021, EN IEC 55014-2:2021, (für Ladegerät hinzufügen) 2014/35/EU, EN 55014-1:2017 / EN 55014-1:2017 +A11:2020, EN 61000-3-2:2014 Klasse A, EN IEC 61000-3-2:2019 +A1:2021 Klasse A, EN 61000-3-3:2013, EN 61000-3-3:2013 +A2:2021, EN 55014-2:1997 +A1:2001 +A2:2008 Kategorie II, (für Akkupack hinzufügen) EN 62133-2:2017+A1:2021

Bevollmächtigter zur Zusammenstellung der technischen Unterlagen in der EU:  
KYOCERA UNIMERCO Fastening A/S, Drejervej 2, DK-7451 Sunds, Tel: +45 97 14 14 40, Herr. Ebbe Hornstrup

Die Seriennummer des Werkzeugs kann dem Deckblatt entnommen werden.

Datum: 06.11.2023



Shoufu XIE  
Geschäftsführer, Taizhou Xindalu Electronic Technology Co., Ltd, Zhejiang, China

**Especificación de la herramienta**

Modelo	TJEP HC-18B
N.º TJEP	103320
Longitud	418 mm
Anchura	113 mm
Altura	305 mm
Peso	7,25 kg
Capacidad de corte	Ø 5 - 18 mm
Fuerza tensil del material	400-500 MPa
Velocidad de corte	3 - 5 segundos
Rotación del cabezal	360°
Alimentación	Batería
Motor	18 V
L <sub>PA</sub>	73,15 dB
L <sub>WA</sub>	81,15 dB
Incertidumbre (L <sub>PA</sub> /L <sub>WA</sub> )	3,0 dB
<sup>a</sup> hwz	2,274 m/s <sup>2</sup>
Incertidumbre ( <sup>a</sup> hwz)	1,50 m/s <sup>2</sup>

*Puede que nuestras herramientas están sometidas a un proceso de desarrollo y mejora continuo, la información de esta sinopsis está sujeta a cambios sin previo aviso. Puede encontrar la información actualizada en [www.tjep.eu](http://www.tjep.eu)*

**Aplicación de la herramienta**

- Para el corte de ferralla, acero al carbono, acero redondo laminado en caliente, etc.

**Accesorios**

Descripción	Descripción
Batería TJEP UniKIT, 18 V 4,0 Ah	Cuchillas
Cargador TJEP UniKIT	

**Declaración de conformidad**

Por la presente, Taizhou Xindalu Electronic Technology Co., Ltd, No. 33, Chengguang Road, Eastern New Center, Wenling, Zhejiang, China

declara bajo responsabilidad exclusiva que la TJEP HC-18B

cumple las directivas, sus modificaciones y las normas: 2011/65/EU, 2006/42/EC, 2014/30/EU, 2012/19/EC, EN 62841-1:2015/A11:2022, EN 62841-2-8:2016, EN IEC 55014-1:2021, EN IEC 55014-2:2021, (añadir para cargador) 2014/35/EU, EN 55014-1:2017 / EN 55014-1:2017 +A11:2020, EN 61000-3-2:2014 Clase A, EN IEC 61000-3-2:2019 +A1:2021 Clase A, EN 61000-3-3:2013, EN 61000-3-3:2013 +A2:2021, EN 55014-2:1997 +A1:2001 +A2:2008 Categoría II, (añadir para bloque de baterías) EN 62133-2:2017+A1:2021

Contacto autorizado en la UE para la compilación de la documentación técnica: KYOCERA UNIMERCO Fastening A/S, Drejervej 2, DK-7451 Sunds, Tel: +45 97 14 14 40, Sr. Ebbe Hornstrup

El número de serie está indicado en la portada.

Fecha: 06/11/2023



Shoufu XIE  
Director, Taizhou Xindalu Electronic Technology Co., Ltd, Zhejiang, China

**Työkälun tiedot**

Malli	TJEP HC-18B
TJEP-nro	103320
Pituus	418 mm
Leveys	113 mm
Korkeus	305 mm
Paino	7,25 kg
Leikkauskapasiteetti	Ø 5 - 18 mm
Materiaalin vetolujuus	400-500 MPa
Leikkausnopeus	3 - 5 sekuntia
Pään kierto	360°
Virtalähde	Akku
Moottori	18 V
L <sub>PA</sub>	73,15 dB
L <sub>WA</sub>	81,15 dB
Epävarmuus (L <sub>PA</sub> /L <sub>WA</sub> )	3,0 dB
<sup>a</sup> hwz	2,274 m/s <sup>2</sup>
Epävarmuus ( <sup>a</sup> hwz)	1,50 m/s <sup>2</sup>

*Koska kehitämme ja parannamme jatkuvasti työkalujamme, tämän yleiskuvauksen tiedot voivat muuttua ilman erillistä ilmoitusta. Päivitetyt tiedot löytyvät osoitteesta [www.tjep.eu](http://www.tjep.eu)*

**Työkälun käyttökohteet**

- Raudoitustankojen, hiiliteräksen, kuumavalsatun pyöröteräksen jne. leikkaamiseen.

**Lisätarvikkeet**

Kuvaus	Kuvaus
TJEP UniKIT -akku, 18V 4,0 Ah	Terät
TJEP UniKIT -laturi	

**Vaatimustenmukaisuusvakuutus**

Me; Taizhou Xindalu Electronic Technology Co., Ltd, No. 33, Chengguang Road, Eastern New Center, Wenling, Zhejiang, Kiina

vakuutamme yksinomaisella vastuullamme, että; TJEP HC-18B

vastaa seuraavia direktiivejä, niiden muutettuja versioita ja standardeja; 2011/65/EU, 2006/42/EC, 2014/30/EU, 2012/19/EC, EN 62841-1:2015/A11:2022, EN 62841-2-8:2016, EN IEC 55014-1:2021, EN IEC 55014-2:2021, (lisää laturia varten) 2014/35/EU, EN 55014-1:2017 / EN 55014-1:2017 +A11:2020, EN 61000-3-2:2014 Clase A, EN IEC 61000-3-2:2019 +A1:2021 Clase A, EN 61000-3-3:2013, EN 61000-3-3:2013 +A2:2021, EN 55014-2:1997 +A1:2001 +A2:2008 Categoría II, (lisää akkua varten) EN 62133-2:2017+A1:2021

Teknisen tiedoston laatimiseen valtuutettu yhteyshenkilö EU:ssa; KYOCERA UNIMERCO Fastening A/S, Drejervej 2, DK-7451 Sunds, Puh.: +45 97 14 14 40, Ebbe Hornstrup

Sarjanumero on merkitty etusivulle.

Päivämäärä; 06.11.2023



Shoufu XIE  
Johtaja Taizhou Xindalu Electronic Technology Co., Ltd, Zhejiang, Kiina

**Spécification de l'outil**

Model	TJEP HC-18B
TJEP n°	103320
Longueur	418 mm
Largeur	113 mm
Hauteur	305 mm
Poids	7,25 kg
Capacité de coupe	Φ 5 - 18 mm
Résistance à la traction des matériaux	400-500 MPa
Vitesse de coupe	3 - 5 secondes
Rotation de la tête	360°
Alimentation électrique	Batterie
Moteur	18 V
L <sub>PA</sub>	73,15 dB
L <sub>WA</sub>	81,15 dB
Incertitude (L <sub>PA</sub> /L <sub>WA</sub> )	3,0 dB
<sup>a</sup> hwz	2,274 m/s <sup>2</sup>
Incertitude ( <sup>a</sup> hwz)	1,50 m/s <sup>2</sup>

Comme nous développons et améliorons constamment nos outils, les informations contenues dans cet aperçu sont susceptibles d'être modifiées sans préavis. Des informations actualisées sont disponibles à l'adresse suivante : [www.tjep.fr](http://www.tjep.fr)

**Application de l'outil**

- Pour couper des barres d'armature, de l'acier au carbone, de l'acier rond laminé à chaud, etc.

**Accessoires**

Description	Description
Batterie TJEP UniKIT, 18 V 4,0Ah	Lames
Chargeur TJEP UniKIT	

**Déclaration de conformité**

Nous, Taizhou Xindalu Electronic Technology Co., Ltd, No. 33, Chenguang Road, Eastern New Center, Wenling, Zhejiang, Chine

déclarons sous notre seule responsabilité ce qui suit : TJEP HC-18B

est conforme à la (aux) directive(s), à ses (leurs) modifications et à ses (leurs) normes ; 2011/65/EU, 2006/42/EC, 2014/30/EU, 2012/19/EC, EN 62841-1:2015/A11:2022, EN 62841-2-8:2016, EN IEC 55014-1:2021, EN IEC 55014-2:2021, (ajout pour le chargeur) 2014/35/EU, EN 55014-1:2017 / EN 55014-1:2017 +A11:2020, EN 61000-3-2:2014 Classe A, EN IEC 61000-3-2:2019 +A1:2021 Classe A, EN 61000-3-3:2013, EN 61000-3-3:2013 +A2:2021, EN 55014-2:1997 +A1:2001 +A2:2008 Catégorie II, (ajout pour la batterie) EN 62133-2:2017+A1:2021

Contact autorisé dans l'UE pour la constitution du dossier technique : KYOCERA UNIMERCO Fastening A/S, Drejervej 2, DK-7451 Sunds, Tél. : +45 97 14 14 40, M. Ebbe Hornstrup

Le numéro de série se trouve sur la première page.

Date : 06.11.2023



Shoufu XIE  
Responsable, Taizhou Xindalu Electronic Technology Co., Ltd, Zhejiang, Chine

**Προδιαγραφές εργαλείου**

Μοντέλο	TJEP HC-18B
TJEP αρ.	103320
Μήκος	418 mm
Πλάτος	113 mm
Ύψος	305 mm
Βάρος	7,25 kg
Ικανότητα κοπής	Φ 5 - 18 mm
Αντοχή υλικού σε εφελκυσμό	400-500 MPa
Ταχύτητα κοπής	3 - 5 δευτερόλεπτα
Περιστροφή κεφαλής	360°
Ηλεκτρική τροφοδοσία	Μπαταρία
Μοτέρ	18 V
L <sub>PA</sub>	73,15 dB
L <sub>WA</sub>	81,15 dB
Αβεβαιότητα (L <sub>PA</sub> /L <sub>WA</sub> )	3,0 dB
<sup>a</sup> hwz	2,274 m/s <sup>2</sup>
Αβεβαιότητα ( <sup>a</sup> hwz)	1,50 m/s <sup>2</sup>

Καθώς αναπτύσσουμε και βελτιώνουμε συνεχώς τα εργαλεία μας, οι πληροφορίες που περιλαμβάνονται σε αυτήν την επισκόπηση μπορεί να αλλάξουν χωρίς προειδοποίηση. Μπορείτε να βρείτε ενημερωμένες πληροφορίες στη διεύθυνση [www.tjep.eu](http://www.tjep.eu)

**Εφαρμογή εργαλείου**

- Για την κοπή ράβδων οπλισμού, ανθρακούχου χάλυβα, στρογγυλού χάλυβα θερμής εξέλασης κ.λπ.

**Παρελκόμενα**

Περιγραφή	Περιγραφή
Μπαταρία TJEP UniKIT, 18 V 4,0 Ah	Λεπίδες
Φορτιστής TJEP UniKIT	

**Δήλωση συμμόρφωσης**

Οι ακόλουθες εταιρείες: Taizhou Xindalu Electronic Technology Co., Ltd, No. 33, Chenguang Road, Eastern New Center, Wenling, Zhejiang, Kίνα

δηλώνουμε με αποκλειστική μας ευθύνη ότι το TJEP HC-18B

συμμορφώνεται με τις οδηγίες, τις τροποποιήσεις και τα πρότυπα 2011/65/EU, 2006/42/EC, 2014/30/EU, 2012/19/EC, EN 62841-1:2015/A11:2022, EN 62841-2-8:2016, EN IEC 55014-1:2021, EN IEC 55014-2:2021, (προσθήκη για φορτιστή) 2014/35/EU, EN 55014-1:2017 / EN 55014-1:2017 +A11:2020, EN 61000-3-2:2014 Τάξη Α, EN IEC 61000-3-2:2019 +A1:2021 Τάξη Α, EN 61000-3-3:2013, EN 61000-3-3:2013 +A2:2021, EN 55014-2:1997 +A1:2001 +A2:2008 Κατηγορία II, (προσθήκη για συστοιχία μπαταριών) EN 62133-2:2017+A1:2021

Εξουσιοδοτημένος υπεύθυνος επικοινωνίας στην Ε.Ε. για τη σύνταξη του τεχνικού φακέλου: KYOCERA UNIMERCO Fastening A/S, Drejervej 2, DK-7451 Sunds, τηλ.: +45 97 14 14 40, K. Ebbe Hornstrup

Ο αριθμός σειράς αναγράφεται στην μπροστινή σελίδα.

Ημερομηνία: 06/11/2023



Shoufu XIE  
Διευθυντής, Taizhou Xindalu Electronic Technology Co., Ltd, Zhejiang, Kίνα

**Specifikacija alata**

Model	TJEP HC-18B
TJEP br.	103320
Duljina	418 mm
Širina	113 mm
Visina	305 mm
Težina	7,25 kg
Kapacitet rezanja	Φ 5 - 18 mm
Vlačna čvrstoća materijala	400-500 MPa
Brzina rezanja	3 - 5 sekundi
Rotacija glave	360°
Napajanje	Baterija
Motor	18 V
L <sub>PA</sub>	73,15 dB
L <sub>WA</sub>	81,15 dB
Nepreciznost (L <sub>PA</sub> /L <sub>WA</sub> )	3,0 dB
<sup>a</sup> hwz	2,274 m/s <sup>2</sup>
Nepreciznost ( <sup>a</sup> hwz)	1,50 m/s <sup>2</sup>

*Neprekidno razvijamo i poboljšavamo svoje alate, a informacije u ovom pregledu mogu se mijenjati bez prethodne obavijesti. Ažurirane informacije dostupne su na [www.tjep.eu](http://www.tjep.eu)*

**Primjena alata**

- Za rezanje armaturnih šipki, ugljičnog čelika, toplo valjanog okruglog čelika itd.

**Pribor**

Opis	Opis
TJEP UniKIT baterija, 18 V 4,0 Ah	Oštrice
TJEP UniKIT punjač	

**Izjava o sukladnosti**

Mi, Taizhou Xindalu Electronic Technology Co., Ltd, No. 33, Chenguang Road, Eastern New Center, Wenling, Zhejiang, China

izjavljujemo pod vlastitom odgovornošću da TJEP HC-18B

ispunjava zahtjeve direktiva, njihovih dopuna i standarda 2011/65/EU, 2006/42/EC, 2014/30/EU, 2012/19/EC, EN 62841-1:2015/A11:2022, EN 62841-2-8:2016, EN IEC 55014-1:2021, EN IEC 55014-2:2021, (dodatak za punjač) 2014/35/EU, EN 55014-1:2017 / EN 55014-1:2017 +A11:2020, EN 61000-3-2:2014 Klasa A, EN IEC 61000-3-2:2019 +A1:2021 Klasa A, EN 61000-3-3:2013, EN 61000-3-3:2013 +A2:2021, EN 55014-2:1997 +A1:2001 +A2:2008 Kategorija II, (dodatak za baterijski modul) EN 62133-2:2017+A1:2021

Ovlaštena osoba u Europskoj uniji za sastavljanje tehničke dokumentacije

KYOCERA UNIMERCO Fastening A/S, Drejervej 2, DK-7451 Sunds, Tel.: +45 97 14 14 40, g. Ebbe Hornstrup

Serijski broj nalazi se na prednjoj stranici.

Datum; 06.11.2023

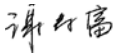

Shoufu XIE  
Menadžer, Taizhou Xindalu Electronic Technology Co., Ltd,  
Zhejiang, China

**Specifiche dell'utensile**

Modello	TJEP HC-18B
TJEP n.	103320
Lunghezza	418 mm
Larghezza	113 mm
Altezza	305 mm
Peso	7,25 kg
Capacità di taglio	Φ 5 - 18 mm
Resistenza alla trazione del materiale	400-500 MPa
Velocità di taglio	3 - 5 secondi
Rotazione della testa	360°
Alimentazione elettrica	Batteria
Motore	18 V
L <sub>PA</sub>	73,15 dB
L <sub>WA</sub>	81,15 dB
Tolleranza (L <sub>PA</sub> /L <sub>WA</sub> )	3,0 dB
<sup>a</sup> hwz	2,274 m/s <sup>2</sup>
Tolleranza ( <sup>a</sup> hwz)	1,50 m/s <sup>2</sup>

*In un'ottica di continuo sviluppo e miglioramento degli utensili, le informazioni qui contenute possono essere modificate senza preavviso. Le informazioni aggiornate sono disponibili sul sito [www.tjep.eu](http://www.tjep.eu)*

**Applicazioni dell'utensile**

- Per il taglio di tondini, acciaio al carbonio, barre tonde di acciaio laminate a caldo ecc.

**Accessori**

Descrizione	Descrizione
Batteria TJEP UniKIT, 18 V 4,0 Ah	Lame
Caricabatterie TJEP UniKIT	

**Dichiarazione di conformità**

L'azienda Taizhou Xindalu Electronic Technology Co., Ltd, No. 33, Chenguang Road, Eastern New Center, Wenling, Zhejiang, Cina

dichiara sotto la sua esclusiva responsabilità che il prodotto TJEP HC-18B

è conforme alle direttive, alle relative modifiche e alle norme 2011/65/EU, 2006/42/EC, 2014/30/EU, 2012/19/EC, EN 62841-1:2015/A11:2022, EN 62841-2-8:2016, EN IEC 55014-1:2021, EN IEC 55014-2:2021, (aggiunta per caricabatterie) 2014/35/EU, EN 55014-1:2017 / EN 55014-1:2017 +A11:2020, EN 61000-3-2:2014 Classe A, EN IEC 61000-3-2:2019 +A1:2021 Classe A, EN 61000-3-3:2013, EN 61000-3-3:2013 +A2:2021, EN 55014-2:1997 +A1:2001 +A2:2008 Categoria II, (aggiunta per pacco batterie) EN 62133-2:2017+A1:2021

Contatto autorizzato alla compilazione del Dossier tecnico nell'UE: KYOCERA UNIMERCO Fastening A/S, Drejervej 2, DK-7451 Sunds, Tel.: +45 97 14 14 40, Mr. Ebbe Hornstrup

Il numero di serie è riportato sulla pagina di copertina.

Data: 06/11/2023



Shoufu XIE  
Manager, Taizhou Xindalu Electronic Technology Co., Ltd,  
Zhejiang, Cina

Explode drawing - TJEP HC-18B

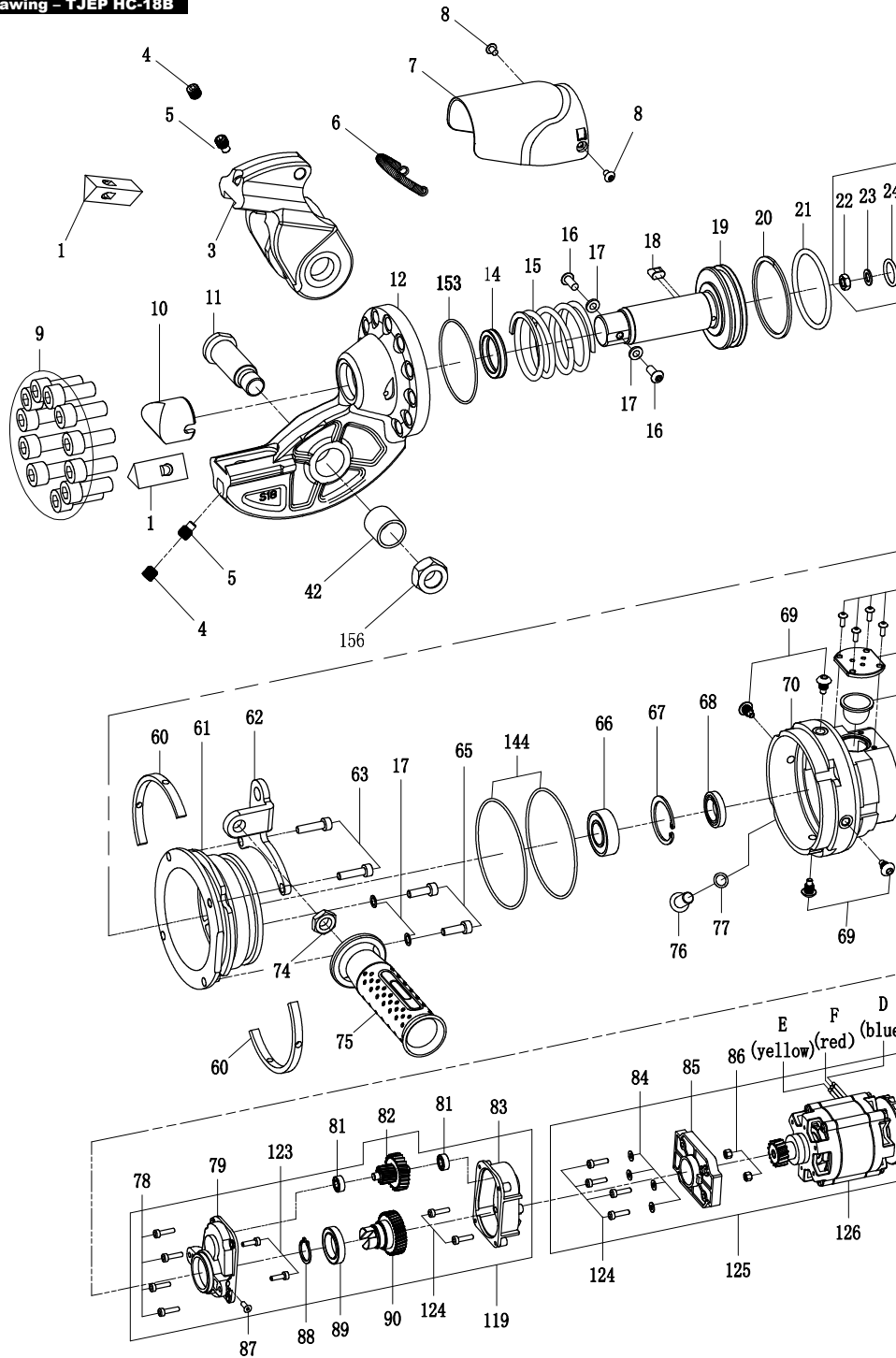



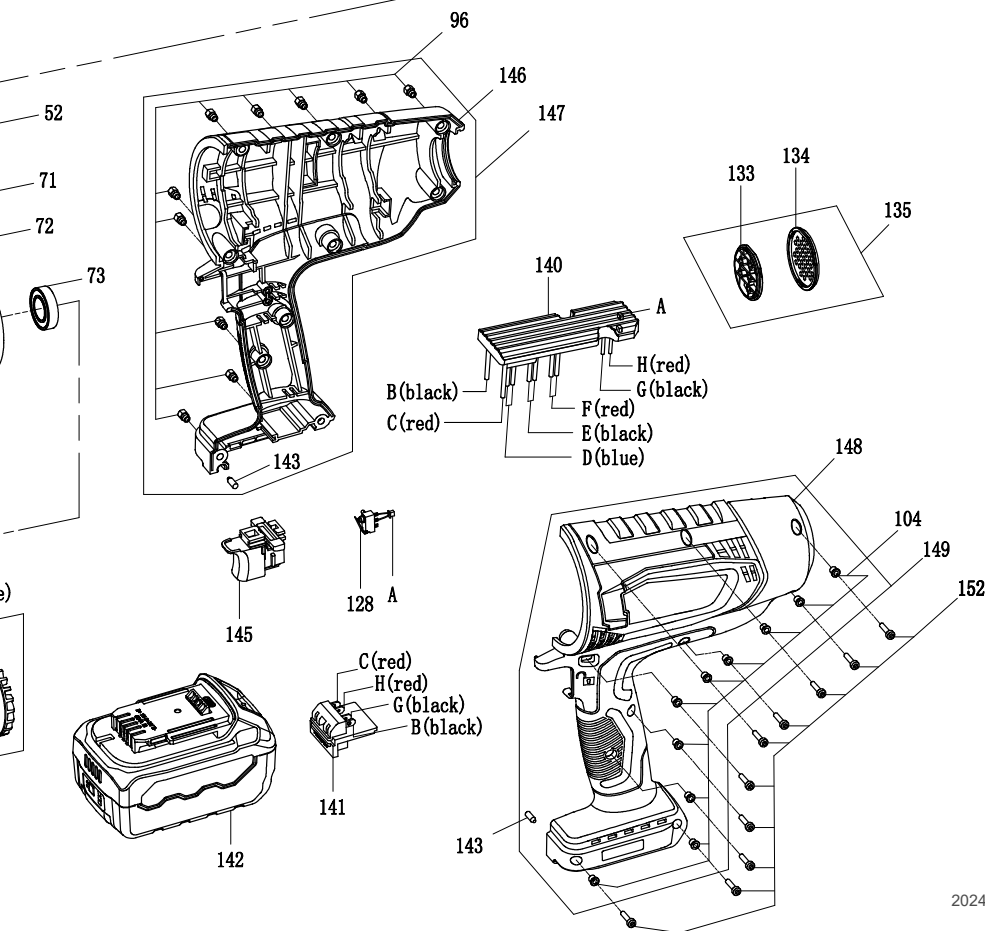
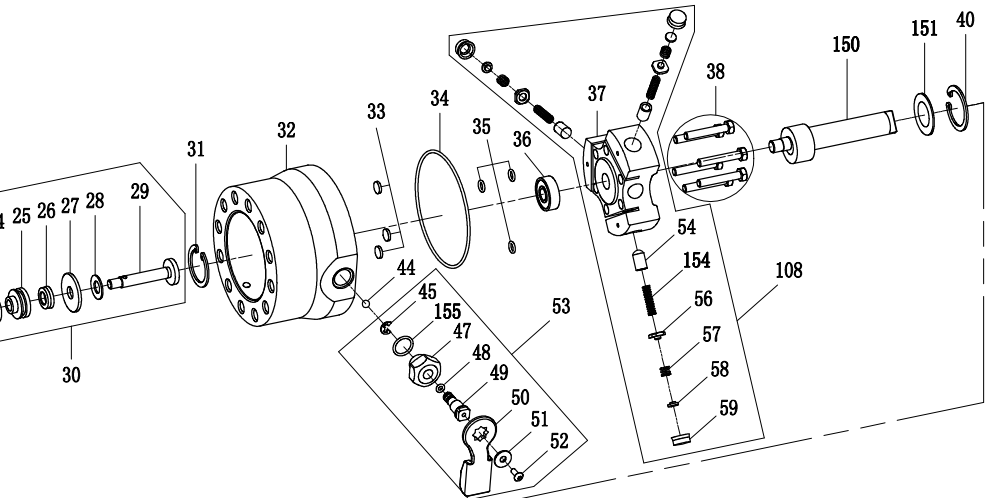

**Spare part list – TJEP HC-18B**

ITEM NO.	PART NO.	DESCRIPTION
1	319209	Blade
3	30202042	Mobile head
4	301305	Hex screw M8×8
5	90201003	Hex screw M8×12
6	316509	Tension Spring
7	316329	Protective Cover
8	301209	Hex screw M4×6
9	301129	Hex screw M8×25
10	316237	Sliding sleeve
11	316235	Rotating Pin
12	30202043	Blade seat
14	311350	Frameless oil seal 1
15	316512	Piston return spring
16	301214	Hex head screw M5×16
17	306007	Flat Washer 1
18	319203	Piston guide key
19	316236	Piston
20	311366	Sealing Washer
21	311354	O-Ring 2
22	300003	Locking nut
23	306009	Flat Washer 2
24	311338	O-Ring 3
25	316241	Oil unloading valve core
26	311365	Frameless oil seal 2
27	316242	Plate
28	301602	φ 8 disc washer
29	316239	Valve rod of oil unloading valve
30	219005-1	Oil unloading valve Unit
31	302211	Circlip 1
32	319207	Pump cylinder
33	309018	Magnetic steel
34	311326	O-Ring 4
35	311358	O-Ring 5
36	303211	Bearing 608
37	316243	Pump
38	301703	Hex Bolt M5×30
40	302209	Circlip 2
42	316225	Rotating pin bushing

ITEM NO.	PART NO.	DESCRIPTION
44	309003	Steel Ball
45	302204	E-Ring Ф4
47	316244	Pressure relief valve body
48	311348	O-Ring 7
49	316245	Valve rod of pressure relief valve
50	319105	Pressure relief valve lever
51	311144	Flat washer 3
52	301202	Button Head Screw M3X8
53	219006-1	Pressure relief valve Unit
54	316248	Plunger
56	316249	Check valve
57	316508	Check valve spring
58	319208	Rubber Cap Pad
59	319905	Rubber Cap
60	316903	Rotating Ring
61	316909	Rotating Box
62	316149	Handle Bracket
63	301119	Hex screw M5×20
65	301120	Hex screw M5×16
66	303213	Bearing 6002
67	302208	Circlip 3
68	311361	Oil Seal
69	319212	Rotating ring limit bolt
70	316910	Oil tank
71	316908	Membrane sac platen
72	319901	Membrane sac
73	303214	Bearing 6902
74	300005	Nut M10
75	316252	Side Handle
76	301210	Hex screw M8×10
77	311349	O-Ring 8
78	301104	Hex screw M3×12
79	316906	Gearbox cover
81	303215	Bearing 618
82	222111	Connecting gear unit
83	316907	Gear box seat
84	306001	Washer
85	316330	Motor connection bracket

ITEM NO.	PART NO.	DESCRIPTION
86	300002	Nut M3
87	90201098	Hex screw M3×8
88	302207	Circlip φ15
89	303216	Bearing 6803
90	316256	Helical gear
96	311277	Nut M3X4
104	311410	Hollow Pin 7
108	219007-1	Pump Assy
119	219018	Gear Box Assy
123	301103-1	Hex screw M3×10
124	301105-1	Hex screw M3×14
125	70102034	Motor Assy
126	70102033	Motor Unit
128	30204002	Trigger Switch
133	30207001	Fixing Plate
134	30207002	Guard Plate
135	70102032	Ventilation filter assy
140	70202001	Main PWB Unit
141	30707018	Electrode Unit
142	90301025-1	Li-ion Battery B1840LB
143	30708002	Rubber block
144	90205003	O-Ring 9
145	70107002	Trigger
146	30207029	Frame L
147	70102029-1	Frame L Assy
148	30207028	Frame R
149	70102028-1	Frame R Assy
150	219022	Eccentric shaft
150-1	303220	Bearing NA4901
151	30203009	Retainer Ring Φ21
152	301105	Hex screw M3×14
153	30208001	O-Ring 1
154	30206008	Plunger spring
155	30208006	O-Ring 6

**Technische specificaties**

Model	TJEP HC-18B
TJEP nr.	103320
Lengte	418 mm
Breedte	113 mm
Hoogte	305 mm
Gewicht	7,25 kg
Knipcapaciteit	Φ 5 - 18 mm
Materiaal treksterkte	400-500 MPa
Knipsnelheid	3 - 5 seconden
Koprotatie	360°
Voeding	Accu
Motor	18 V
L <sub>PA</sub>	73,15 dB
L <sub>WA</sub>	81,15 dB
Onzekerheid (L <sub>PA</sub> /L <sub>WA</sub> )	3,0 dB
<sup>a</sup> hwz	2,274 m/s <sup>2</sup>
Onzekerheid ( <sup>a</sup> hwz)	1,50 m/s <sup>2</sup>

Aangezien wij onze producten voortdurend doorontwikkelen en verbeteren, kan de informatie in dit overzicht zonder voorafgaande kennisgeving worden gewijzigd. Actuele informatie is te vinden op [www.tjep-benelux.nl](http://www.tjep-benelux.nl)

**Gebruik van het gereedschap**

- Voor betonstaal, koolstofstaal, warmgewalst rondstaal enz. knippen.

**Accessoires**

Omschrijving	Omschrijving
TJEP UniKIT-accu, 18 V 4,0 Ah	Messen
TJEP UniKIT-oplader	

**Verklaring van overeenstemming**

Wij:  
Taizhou Xindalu Electronic Technology Co., Ltd, No. 33, Chengu-ang Road, Eastern New Center, Wenling, Zhejiang, China

verklaren geheel onder eigen verantwoordelijkheid dat de:  
TJEP HC-18B

in overeenstemming is met de richtlijn(en), de wijziging(en) en de norm(en);

2011/65/EU, 2006/42/EC, 2014/30/EU, 2012/19/EC, EN 62841-1:2015/A11:2022, EN 62841-2-8:2016, EN IEC 55014-1:2021, EN IEC 55014-2:2021, (toevoegen voor acculader) 2014/35/EU, EN 55014-1:2017 / EN 55014-1:2017 +A11:2020, EN 61000-3-2:2014 Klasse A, EN IEC 61000-3-2:2019 +A1:2021 Klasse A, EN 61000-3-3:2013, EN 61000-3-3:2013 +A2:2021, EN 55014-2:1997 +A1:2001 +A2:2008 Categorie II, (toevoegen voor accupakket) EN 62133-2:2017+A1:2021

Geautoriseerde contactpersoon in de EU om het Technisch Dossier samen te stellen;  
KYOCERA UNIMERCO Fastening A/S, Drejervej 2, DK-7451 Sunds, Tel: +45 97 14 14 40, dhr. Ebbe Hornstrup

Het serienummer staat op het titelblad.

Datum: 06-11-2023



Shoufu XIE  
Manager, Taizhou Xindalu Electronic Technology Co., Ltd, Zhejiang, China

**Tekniske spesifikasjoner**

Modell	TJEP HC-18B
TJEP-nr.	103320
Lengde	418 mm
Bredde	113 mm
Høyde	305 mm
Vekt	7,25 kg
Skjærekapasitet	Φ 5 - 18 mm
Materialets strekkfasthet	400-500 MPa
Skjærehastighet	3 - 5 sekunder
Hoderotasjon	360°
Strømforsyning	Batteri
Motor	18 V
L <sub>PA</sub>	73,15 dB
L <sub>WA</sub>	81,15 dB
Usikkerhet (L <sub>PA</sub> /L <sub>WA</sub> )	3,0 dB
<sup>a</sup> hwz	2,274 m/s <sup>2</sup>
Usikkerhet ( <sup>a</sup> hwz)	1,50 m/s <sup>2</sup>

Fordi vi kontinuerlig utvikler og forbedrer produktene våre, kan informasjonen i denne oversikten bli endret uten varsel. Du finner oppdatert informasjon på [www.tjep.no](http://www.tjep.no)

**Verktøybruk**

- For kapping av armeringsjern, karbonstål, varmvalset rundstål osv.

**Tilbehør**

Beskrivelse	Beskrivelse
TJEP UniKIT-batteri, 18 V, 4,0 Ah	Kniver
TJEP UniKIT-lader	

**Samsvarserklæring**

Vi;  
Taizhou Xindalu Electronic Technology Co., Ltd, No. 33, Chengu-ang Road, Eastern New Center, Wenling, Zhejiang, China  
erklærer under eget ansvar at:  
TJEP HC-18B

er i samsvar med direktivet(-ene), endringen(e) og standard(ene);  
2011/65/EU, 2006/42/EC, 2014/30/EU, 2012/19/EC, EN 62841-1:2015/A11:2022, EN 62841-2-8:2016, EN IEC 55014-1:2021, EN IEC 55014-2:2021, (legg til for lader) 2014/35/EU, EN 55014-1:2017 / EN 55014-1:2017 +A11:2020, EN 61000-3-2:2014 Class A, EN IEC 61000-3-2:2019 +A1:2021 Class A, EN 61000-3-3:2013, EN 61000-3-3:2013 +A2:2021, EN 55014-2:1997 +A1:2001 +A2:2008 Category II, (legg til for batteripakke) EN 62133-2:2017+A1:2021

Autorisert kontakt i EU for å sette sammen den tekniske filen:  
KYOCERA UNIMERCO Fastening A/S, Drejervej 2, DK-7451 Sunds, Tlf: +45 97 14 14 40, hr. Ebbe Hornstrup

Serienummeret finnes på forsiden.

Dato: 06.11.2023



Shoufu XIE  
Leder, Taizhou Xindalu Electronic Technology Co., Ltd, Zhejiang, China

**Specyfikacja narzędzia**

Model	TJEP HC-18B
Nr TJEP	103320
Długość	418 mm
Szerokość	113 mm
Wysokość	305 mm
Masa	7,25 kg
Wydajność cięcia	Φ 5 - 18 mm
Wytrzymałość materiału na rozciąganie	400-500 MPa
Prędkość cięcia	3 - 5 sekundy
Obrót głowicy	360°
Zasilanie	Akumulator
Silnik	18 V
L <sub>PA</sub>	73,15 dB
L <sub>WA</sub>	81,15 dB
Niepewność (L <sub>PA</sub> /L <sub>WA</sub> )	3,0 dB
<sup>a</sup> hwz	2,274 m/s <sup>2</sup>
Niepewność ( <sup>a</sup> hwz)	1,50 m/s <sup>2</sup>

Ponieważ nieustannie pracujemy nad rozwojem i ulepszaniem naszych narzędzi, informacje zawarte w niniejszym omówieniu mogą ulegać zmianom bez uprzedzenia. Aktualne informacje są dostępne na stronie [www.tjep.eu](http://www.tjep.eu)

**Zastosowanie narzędzia**

- Do cięcia prętów zbrojeniowych, stali węglowej, walcowanej na gorąco stali okrągłej itp.

**Akcesoria**

Opis	Opis
Akumulator TJEP UniKIT, 18 V 4,0 Ah	Ostrza
Ładowarka TJEP UniKIT	

**Deklaracja zgodności**

My:  
Taizhou Xindalu Electronic Technology Co., Ltd, No. 33, Chengu-ang Road, Eastern New Center, Wenling, Zhejiang, China

oświadczamy na własną odpowiedzialność, że:  
TJEP HC-18B

jest zgodna z dyrektywami, ich poprawkami i normami:  
2011/65/EU, 2006/42/EC, 2014/30/EU, 2012/19/EC, EN 62841-1:2015/A11:2022, EN 62841-2-8:2016, EN IEC 55014-1:2021, EN IEC 55014-2:2021, (dodaj – ładowarka) 2014/35/EU, EN 55014-1:2017 / EN 55014-1:2017 +A11:2020, EN 61000-3-2:2014 Klasse A, EN IEC 61000-3-2:2019 +A1:2021 Klasse A, EN 61000-3-3:2013, EN 61000-3-3:2013 +A2:2021, EN 55014-2:1997 +A1:2001 +A2:2008 Kategori II, (dodaj – akumulator) EN 62133-2:2017+A1:2021

Autoryzowany kontakt w UE, odpowiedzialny za złożenie dokumentacji technicznej;  
KYOCERA UNIMERCO Fastening A/S, Drejervej 2, DK-7451 Sunds, tel.: +45 97 14 14 40, pan Ebbe Hornstrup

Numer seryjny podano na pierwszej stronie.

Data: 06.11.2023



Shoufu XIE  
Kierownik, Taizhou Xindalu Electronic Technology Co., Ltd, Zhejiang, China

**Specificațiile uneltei**

Model	TJEP HC-18B
Nr. TJEP	103320
Lungime	418 mm
Lățime	113 mm
Înălțime	305 mm
Greutate	7,25 kg
Capacitate de tăiere	Φ 5 - 18 mm
Rezistența la întindere a materialului	400-500 MPa
Viteza de tăiere	3 - 5 secunde
Rotăția capului	360°
Alimentarea cu energie electrică	Baterie
Motor	18 V
L <sub>PA</sub>	73,15 dB
L <sub>WA</sub>	81,15 dB
Incertitudine (L <sub>PA</sub> /L <sub>WA</sub> )	3,0 dB
<sup>a</sup> hwz	2,274 m/s <sup>2</sup>
Incertitudine ( <sup>a</sup> hwz)	1,50 m/s <sup>2</sup>

Deoarece dezvoltăm și îmbunătățim constant uneltele noastre, informațiile din această prezentare generală pot fi modificate fără notificare prealabilă. Informațiile actualizate pot fi accesate la adresa [www.tjep.eu](http://www.tjep.eu)

**Aplicația uneltei**

- Pentru tăierea armăturii de fier-beton, a oțelului carbon, a oțelului rotund laminat la cald etc.

**Accesorii**

Descriere	Descriere
Baterie TJEP UniKIT, 18V 4,0 Ah	Lame
Încărcător TJEP UniKIT	

**Deklararea de conformitate**

Noi,  
Taizhou Xindalu Electronic Technology Co., Ltd, No. 33, Chengu-ang Road, Eastern New Center, Wenling, Zhejiang, China

declarăm pe propria răspundere că următorul produs,  
TJEP HC-18B

este în conformitate cu directiva (directivile), modificarea (modificările) și standardul (standardele) aferente:  
2011/65/EU, 2006/42/EC, 2014/30/EU, 2012/19/EC, EN 62841-1:2015/A11:2022, EN 62841-2-8:2016, EN IEC 55014-1:2021, EN IEC 55014-2:2021, (a se adăuga pentru încărcător) 2014/35/EU, EN 55014-1:2017 / EN 55014-1:2017 +A11:2020, EN 61000-3-2:2014 Clasa A, EN IEC 61000-3-2:2019 +A1:2021 Clasa A, EN 61000-3-3:2013, EN 61000-3-3:2013 +A2:2021, EN 55014-2:1997 +A1:2001 +A2:2008 Categoria II, (a se adăuga pentru baterii) EN 62133-2:2017+A1:2021

Persoană de contact autorizată în UE pentru a întocmi Fișa tehnică;  
KYOCERA UNIMERCO Fastening A/S, Drejervej 2, DK-7451 Sunds, Tel: +45 97 14 14 40, DI Ebbe Hornstrup

Numărul de serie este disponibil pe copertă.

Data: 06.11.2023

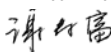

Shoufu XIE  
Manager, Taizhou Xindalu Electronic Technology Co., Ltd, Zhejiang, China

**Vektygsspecifikation**

Modell	TJEP HC-18B
TJEP-nr	103320
Längd	418 mm
Bredd	113 mm
Höjd	305 mm
Vikt	7,25 kg
Skärkapacitet	Φ 5 - 18 mm
Materialets draghållfasthet	400-500 MPa
Skärhastighet	3 - 5 sekunder
Huvudrotation	360°
Strömförsörjning	Batteri
Motor	18 V
L <sub>TPA</sub>	73,15 dB
L <sub>WA</sub>	81,15 dB
Osäkerhet (L <sub>PA</sub> /L <sub>WA</sub> )	3,0 dB
<sup>a</sup> hwz	2,274 m/s <sup>2</sup>
Osäkerhet ( <sup>a</sup> hwz)	1,50 m/s <sup>2</sup>

*Då vi ständigt utvecklar och förbättrar våra verktyg kan informationen i den här översikten komma att ändras utan föregående meddelande. Uppdaterad information finns på [www.tjep.se](http://www.tjep.se)*

**Verktygstillämpning**

- För skärning av armeringsjärn, kolstål, varmvalsad rundstång av stål m.m.

**Tillbehör**

Beskrivning	Beskrivning
TJEP UniKIT batteri, 18 V 4,0 Ah	Knivar
TJEP UniKIT laddare	

**Försäkran om överensstämmelse**

Vi;  
Taizhou Xindalu Electronic Technology Co., Ltd, No. 33, Chengu-ang Road, Eastern New Center, Wenling, Zhejiang, China

försäkrar helt på eget ansvar att:  
TJEP HC-18B

överensstämmer med direktivet/direktiverna, dess ändring(ar) och standard(er);  
2011/65/EU, 2006/42/EC, 2014/30/EU, 2012/19/EC, EN 62841-1:2015/A11:2022, EN 62841-2-8:2016, EN IEC 55014-1:2021, EN IEC 55014-2:2021, (tillägg för laddare) 2014/35/EU, EN 55014-1:2017 / EN 55014-1:2017 +A11:2020, EN 61000-3-2:2014 Klass A, EN IEC 61000-3-2:2019 +A1:2021 Klass A, EN 61000-3-3:2013, EN 61000-3-3:2013 +A2:2021, EN 55014-2:1997 +A1:2001 +A2:2008 Kategori II, (tillägg för batteripaket) EN 62133-2:2017+A1:2021

Behörig kontakt i EU för att sammanställa den tekniska dokumentationen;  
KYOCERA UNIMERCO Fastening A/S, Drejervej 2, DK-7451 Sunds, Tfn: +45 97 14 14 40, Ebbe Hornstrup

Serienummer finns på framsidan.

Datum: 2023-11-06



Shoufu XIE  
Chef, Taizhou Xindalu Electronic Technology Co., Ltd, Zhejiang, China

**Technické špecifikácie**

Model	TJEP HC-18B
Č. TJEP	103320
Dĺžka	418 mm
Šírka	113 mm
Výška	305 mm
Hmotnosť	7,25 kg
Rezná kapacita	Φ 5 - 18 mm
Pevnosť materiálu v ťahu	400-500 MPa
Rýchlosť rezania	3 - 5 sekúnd
Otáčanie hlavy	360°
Napájanie	Batéria
Motor	18 V
L <sub>TPA</sub>	73,15 dB
L <sub>WA</sub>	81,15 dB
Neistota (L <sub>PA</sub> /L <sub>WA</sub> )	3,0 dB
<sup>a</sup> hwz	2,274 m/s <sup>2</sup>
Neistota ( <sup>a</sup> hwz)	1,50 m/s <sup>2</sup>

*Vzhľadom na to, že naše produkty neustále vyvíjame a vylepšujeme, informácie v tejto príručke sa môžu zmeniť bez predchádzajúceho upozornenia. Aktualizované informácie nájdete na adrese [www.tjep.eu](http://www.tjep.eu)*

**Použitie nástroja**

- Na rezanie tyčí, uhlíkovej ocele, kruhovej ocele valcovanej za tepla atď.

**Príslušenstvo**

Popis	Popis
Batéria TJEP UniKIT, 18 V, 4,0 Ah	Čepele
Nabíjačka TJEP UniKIT	

**Vyhlasenie o zhode**

My  
Taizhou Xindalu Electronic Technology Co., Ltd, No. 33, Chengu-ang Road, Eastern New Center, Wenling, Zhejiang, Čína

vyhlasujeme na vlastnú zodpovednosť, že  
TJEP HC-18B

je v súlade s platným znením nasledujúcich smerníc a noriem:  
2011/65/EU, 2006/42/EC, 2014/30/EU, 2012/19/EC, EN 62841-1:2015/A11:2022, EN 62841-2-8:2016, EN IEC 55014-1:2021, EN IEC 55014-2:2021, (pridať pre nabíjačku) 2014/35/EU, EN 55014-1:2017 / EN 55014-1:2017 +A11:2020, EN 61000-3-2:2014 Trieda A, EN IEC 61000-3-2:2019 +A1:2021 Trieda A, EN 61000-3-3:2013, EN 61000-3-3:2013 +A2:2021, EN 55014-2:1997 +A1:2001 +A2:2008 Kategória II, (pridať pre batériu) EN 62133-2:2017+A1:2021

Autorizovaný partner v EÚ na zostavenie technickej dokumentácie;  
KYOCERA UNIMERCO Fastening A/S, Drejervej 2, DK-7451 Sunds, Tel: +45 97 14 14 40, p. Ebbe Hornstrup

Sériové číslo nájdete na prednej strane.

Dátum: 06.11.2023

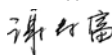

Shoufu XIE  
Manažér, Taizhou Xindalu Electronic Technology Co., Ltd, Zhejiang, Čína

**Tehnične specifikacije**

Model	TJEP HC-18B
Št. TJEP	103320
Dolžina	418 mm
Širina	113 mm
Višina	305 mm
Masa	7,25 kg
Rezalna zmogljivost	Φ 5 - 18 mm
Natezna trdnost materiala	400-500 MPa
Rezalna hitrost	3 - 5 sekund
Zasuk glave	360°
Napajanje	Akumulatorska baterija
Motor	18 V
L <sub>PA</sub>	73,15 dB
L <sub>WA</sub>	81,15 dB
Negotovost (L <sub>PA</sub> /L <sub>WA</sub> )	3,0 dB
<sup>a</sup> hwz	2,274 m/s <sup>2</sup>
Negotovost (+hwz)	1,50 m/s <sup>2</sup>

*Nenehno si prizadevamo za nadaljnji razvoj in izboljševanje naših izdelkov, zato si pridržujemo pravico do sprememb podatkov v tem pregledu brez predhodnega obvestila. Posodobljeni podatki so na voljo na spletnem mestu [www.tjep.eu](http://www.tjep.eu)*

**Uporaba za orodja**

- Za rezanje armaturnih palic, ogljikovega jekla, vroče valjane-ga okroglega jekla ipd.

**Dodatki**

Opis	Opis
Baterija TJEP UniKIT, 18 V 4,0 Ah	Rezila
Polnilnik TJEP UniKIT	

**Izjava o skladnosti**

Podjetje  
Taizhou Xindalu Electronic Technology Co., Ltd, No. 33, Chengu-ang Road, Eastern New Center, Wenling, Zhejiang, Kitajska  
na lastno odgovornost izjavlja, da je  
TJEP HC-18B

skladen z direktivo(-ami), njenimi/njihovimi spremembami in standardom(-i):

2011/65/EU, 2006/42/EC, 2014/30/EU, 2012/19/EC, EN 62841-1:2015/A11:2022, EN 62841-2-8:2016, EN IEC 55014-1:2021, EN IEC 55014-2:2021, (dod. za polnilnik) 2014/35/EU, EN 55014-1:2017 / EN 55014-1:2017 +A11:2020, EN 61000-3-2:2014 Razred A, EN IEC 61000-3-2:2019 +A1:2021 Razred A, EN 61000-3-3:2013, EN 61000-3-3:2013 +A2:2021, EN 55014-2:1997 +A1:2001 +A2:2008 Kategorija II, (dod. za akumulatorski sklop) EN 62133-2:2017+A1:2021

Oseba v EU, pooblaščenca za sestavljanje tehnične dokumentacije:  
KYOCERA UNIMERCO Fastening A/S, Drejervej 2, DK-7451 Sunds,  
Tel: +45 97 14 14 40, g. Ebbe Hornstrup

Serijska številka je navedena na naslovni strani.

Datum: 06. 11. 2023



Shoufu XIE  
Vodja, Taizhou Xindalu Electronic Technology Co., Ltd, Zhejiang,  
Kitajska



KYOCERA UNIMERCO Fastening A/S  
Drejervej 2  
DK-7451 Sunds  
Tlf. +45 97 14 14 40  
Fax +45 97 14 14 86  
[tjep@kyocera-unimerco.com](mailto:tjep@kyocera-unimerco.com)