

CarryVac 3

Portable fume extractor



CarryVac 3 is a small, lightweight and portable fume extraction unit used to maintain a healthy work environment by extracting fumes directly at the source in light duty welding applications.

Designed to be carried to the working area, it can be connected to either a fume extraction welding torch or to the extraction nozzle to extract fumes.

Weld fumes are filtered and captured in a hygienically-packed filter that offers complete protection from particles keeping them isolated from welders even when performing a filter change.

Welding Process

- Welding, GMAW (MIG/MAG)
- Welding, GTAW (TIG)
- Welding, PAW -Plasma Arc Welding
- Welding, SMAW/MMA (Stick)

- Nanofiber filter with extended dust holding capacity and 99% efficiency in capturing welding fumes
- Manual and automatic start/stop function which increases the service life of each filter and of the unit itself
- Adjustable flow to adapt to different torches and hoods
- Automatic flow adjustment to maintain correct airflow and suction during operations
- Alarm notifications
- ISO 21904 compatible for industry standards compliance
- Suitable for fume extraction for light welding applications

Visit esab.com for more information.



TM-200

PM-300

TM-80

Suction Nozzles

CarryVac 3

Specifications	
Primary Voltage	110/230 VAC ± 15% , 1ph, 50/60 Hz
Power	1250 W (110-120V) 1300 W (220-240V)
Filter Surface	5.3 m ² (17.4 ft ²)
Noise Level (at 1m/3ft, 100% motor power, ISO 11201)	79 dB(A)
Operating Temperature	0 to +35 °C (+32 to +95 °F)
Storage Temperature	-20 to +60 °C (-4 to +140 °F)
Extraction Capacity	180 m ³ /h (106 cfm)
Extraction Capacity, 5 m Hose	165 m ³ /h (97 cfm)
Filter Efficiency	>99 %
Standards (Filter)	(ISO 21904-2) F9 (EN779) MERV 14 (ASHRAE 52.2)
Standards (Unit)	EN ISO 21904-1:2020, EN ISO 12100:2010, EN ISO 20607:2019 EN 61000-6-2:2019, EN 61000-6-4:2019 EN 61000-3-3:2013, EN 60204-1:2018
Max. Vacuum (generated by the motor)	25 kPa
Max. Vacuum (at hose connection)	18 kPa
Hose Diameter	50 mm (2 in.)
Dimensions L x W x H	800 x 222 x 406 mm (31 x 8.7 x 15.9 in.)
Weight	14.8 kg (32.6 lbs)

Ordering Information	
Description	Part Number
CarryVac 3 AST, 230V, EU	0700003890
CarryVac 3 AST, 110V, UK	0700003891
CarryVac 3 AST, 110V, US	0700003892
CarryVac 3 AST, 230V, EU Hose Connection	0700003893

Delivery includes: Fume extraction unit complete with hose superflex crushproof Ø50 2.5 m (8 ft), 2x hose connection M50 Ø50mm, sensor clamp, filter and instruction manual.

Wears & Spares		
No	Description	Part Number
1	Filter nano disposable	0700003903
2	Motor 1250W 110V	0700003904
3	Motor 1300W 230V	0700003905
4	Sensor clamp	0700003091
5	Kit motor gaskets	0700003906
6	Control unit	0700003907
7	Hose superflex crushproof Ø50mm 2.5 m (8 ft)	0700003908
8	Hose connection M50 Ø50mm	0700003909
9	Pre-separator	0700003910
10	Motor cover w.overlay	0700003911

CarryVac 3

Wears & Spares, cont.

No	Description	Part Number
11	Switch 3-pos.	0464663106
12	Kit sound sealing	0700003912
13	Fuse 5x20mm 6,3AT (10 pieces)	0700003913
14	Fuse 5x20mm 12AT (10 pieces)	0700003914
15	Handle kit	0464663078

Options & Accessories

No	Description	Part Number
16	Pre filter	0700003014
17	Pre filter *	0468455002
18	Suction nozzle TM-80, 80 mm round	0700003221
19	Suction nozzle TM-200, 200 mm wide	0700003222
20	Suction nozzle PM-300, 300 mm wide	0700003223
21	Hose superflex crushproof Ø50 5 m	0700003917
22	Hose superflex crushproof Ø50 15 m	0700003918
23	Fume torch adaptor	0464663043
24	Hose connection M50 Ø50	0700003919

* complete

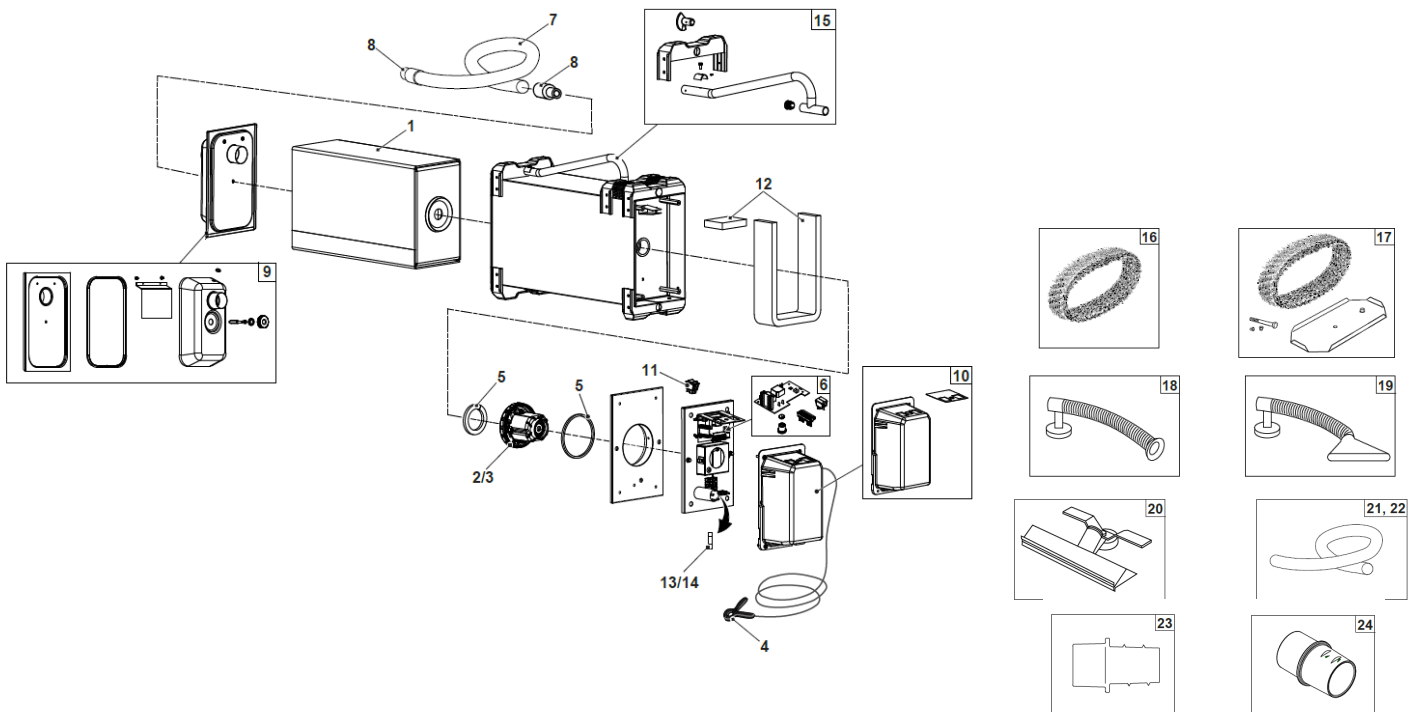

ESAB / esab.com

