

This document is our property and shall not without our permission be altered, copied, used for manufacturing or communicated to any other person or company.

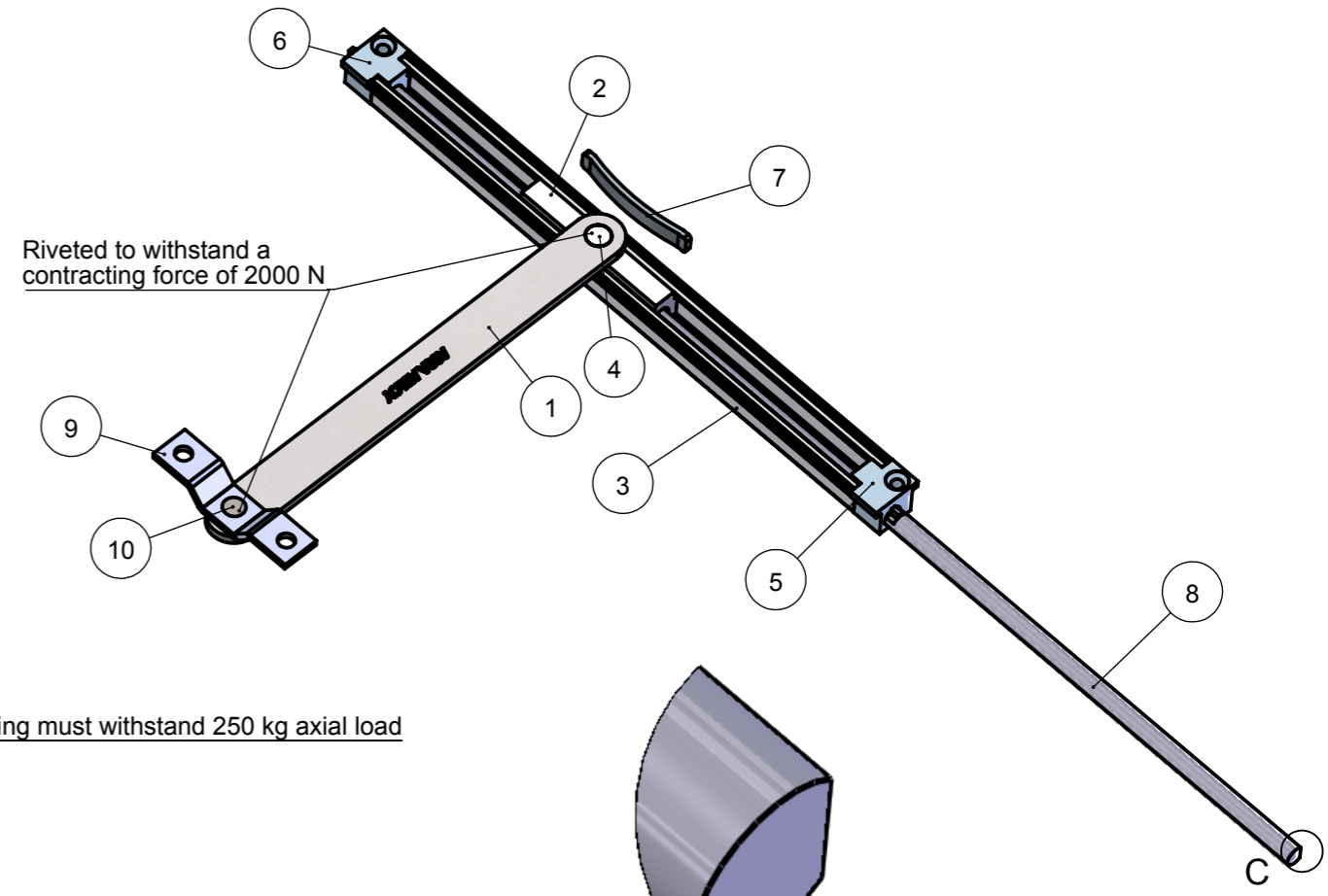
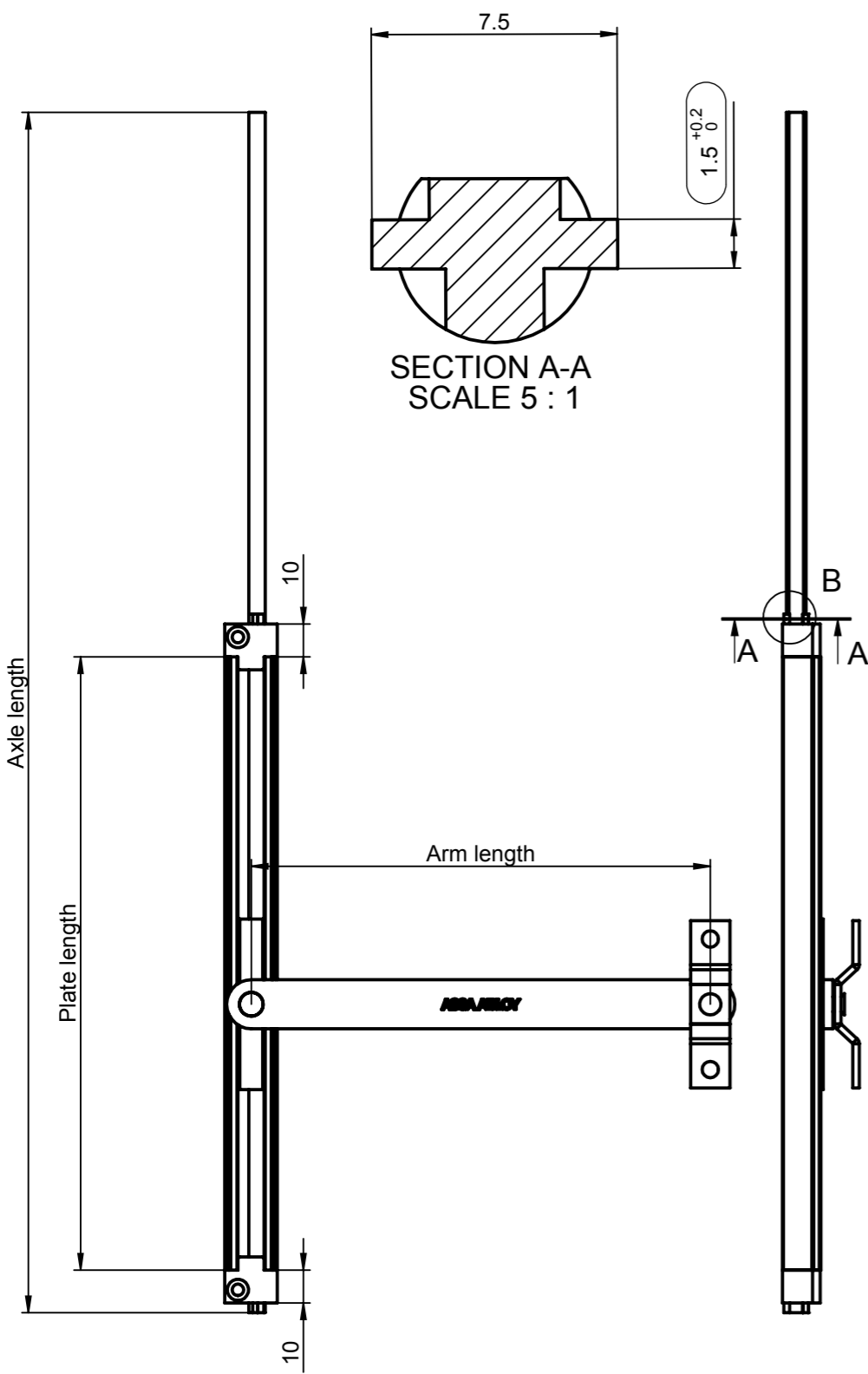

Friction:
 Min 150 N (15 kg) Engaged 55°
 Max 1 N (0,1kg) Disengaged 0°

Pos	qty	Document name	Name	Alternate ID	Document ID
10	1	Rivet		3940	00000486
9	1	Bracket		C1087	D000033544
8	1	Shaft		2221	D000000304
7	1	Spring		000102417	D000102417-001
6	1	Supporting component	Back	5794	D000032899
5	1	Supporting component	Front	5793	D000032896
4	1	Rivet	∅5.6 mm	5797	D000037757
3	1	Case		5789	D000037755
2	1	Sliding component		000102433	D000102433-001
1	1	Arm		4956	D000030117

Article number	Plate mm	Axle mm	Arm mm
0751 1	187	366	140
0751 2	237	458	205
0751 3	337	656	280
0751 4	437	906	450

Surface: Material: General tolerance: ISO 2768-mH
 Material <not specified>

Volume: Weight: 186.26 Surface area: created: 2012-09-07 designed by: DaRu changed by: DaRu Scale: 1:2 (A3) Projection:

ASSA ABLOY
ASSA ABLOY Scandinavia

Window holder
0751

Alternate ID: **0751**
Document ID: **D000761821-001** Rev.: **1**

Approved 2018-11-07

Part/assy:D000761821-001

Configuration:Default

SHEET 1 OF 1